

European Technical Assessment

ETA-20/1337 of 07/01/2021

General Part

Technical Assessment Body Issuing the European Technical Assessment:	Element Materials Technology Rotterdam B.V.
Trade Name of the Construction Product:	Astro Thermal Fire PS Fire Sleeve; Astro Thermal Fire PS+ Fire Sleeve; Astro DS Duct Sleeve, Astro DS Duct Sleeve+ and Astro DS+ Low Profile (LP) Duct Sleeve
Product Family to Which the Construction Product Belongs:	EC PAC 35
Manufacturer:	Astroflame (Fire Seals) Ltd Intumescent House Unit 8, The IO Centre Stephensworth Fareham Hampshire PO15 5RU
Manufacturing Plant(s):	As held on File by Element
This European Technical Assessment Contains:	66 Pages including 05 Annexes which form an integral part of this Assessment
This European Technical Assessment is Issued in Accordance with Regulation (EU) No 305/2011, on the Basis of:	EAD 350454-00-1104 – “Fire Stopping and Fire Sealing Products - Penetration Seals”
This Version Replaces:	ETA 14/0117, Issued on 18/01/2019

Translations of this European Technical Assessment in other languages shall fully correspond to the original issued document and should be identified as such.

Communication of the European Technical Assessment, including transmission by electronic means, shall be in full (except the confidential Annexes referred to above. However, a partial reproduction may be made, with the written consent of the issuing Technical Assessment Body. Any partial reproduction has to be identified as such.

II SPECIFIC CONDITIONS OF THE EUROPEAN TECHNICAL ASSESSMENT

1 Technical Description of Product and Intended Use

1.1 Technical Description of the Product

Astro Thermal Fire PS Fire Sleeve; Astro Thermal Fire PS+ Fire Sleeve; Astro DS Duct Sleeve, Astro DS Duct Sleeve+ and Astro DS+ Low Profile (LP) Duct Sleeve are pipe closure devices installed around metal and plastic pipes (including PVC-U circular and rectangular ambient pressure extraction and ventilation 'duct' type pipes) to form a penetration seal to reinstate the fire resistance performance of non-loadbearing wall and floor constructions, where they have been provided with apertures for the penetration of services.

1.1.1 Type of Penetration Seal System:

Pipe closure device - Intumescent Sleeve.

Astro Thermal Fire PS; Astro Thermal Fire PS+ Fire Sleeve consists of an Intumescent sleeve.

1.1.1.1 *Astro Thermal Fire PS Fire Sleeve - Circular*

The Astro Thermal Fire PS Fire sleeve is a flexible Intumescent material consisting primarily of mineral fibres intercalated graphite and organic binders and is formed into a pipe sleeve shape. It is grey / dark grey in colour with a glass fibre reinforced aluminium foil cladding around its perimeter for its full length. It has a nominal 25mm wall thickness. It may be cut down its length to aid fitment around the pipe service and a strip of aluminium foil tape used to seal over the joint.

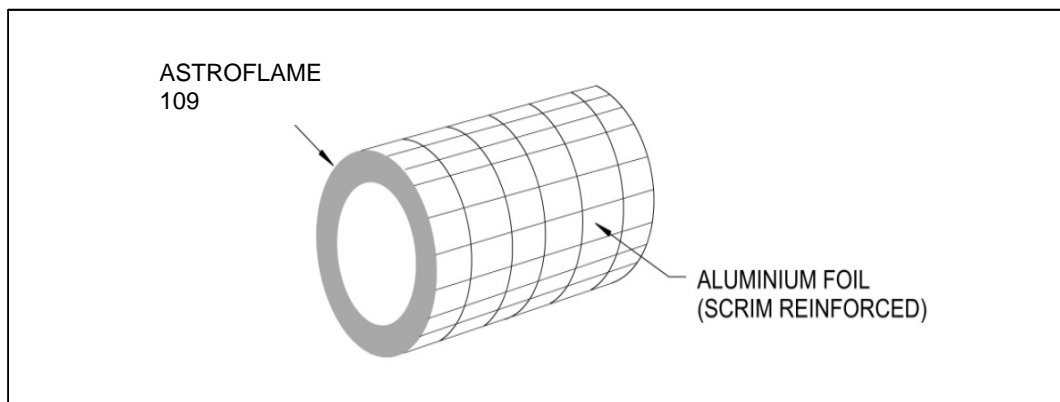

1.1.1.2 Astro Thermal Fire PS+ Fire Sleeve - Circular

The Astro Thermal Fire PS+ Fire Sleeve is as the Astro Thermal Fire PS Fire Sleeve with the addition of further full length 4mm thick flexible Intumescent material located internally within the Astro Thermal Fire PS Sleeve. The additional Intumescent is a 4mm thick Astroflame 107 flexible material consisting primarily of mineral fibres intercalated graphite and organic binders. It is grey in colour. It may be cut down its length to aid fitment around the pipe service and a strip of aluminium foil tape used to seal over the joint.

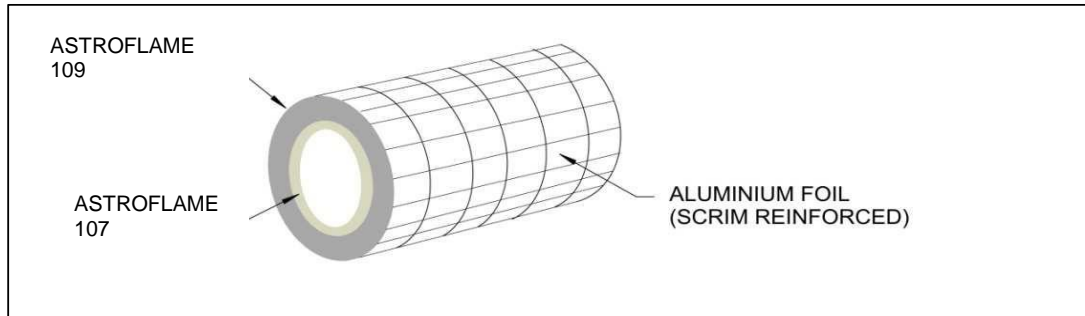

1.1.1.3 Astro DS+ Low Profile (LP) Duct Sleeve - Circular

The Astro DS+ Low Profile (LP) Duct Sleeve is as the Astro Thermal Fire PS+ Fire Sleeve with the thickness of the 109 sleeve element reduced for use in specific circumstances. It is grey in colour. It may be cut down its length to aid fitment around the pipe/duct service and a strip of aluminium foil tape used to seal over the joint. For specific circumstances the Astroflame 107 material may be installed as 1No 4mm thick layer (Standard Sleeve) or as 2No 4mm thick layers (Enhanced Sleeve) as shown below.

'Standard' Sleeve – 1 Layer of Astroflame 107

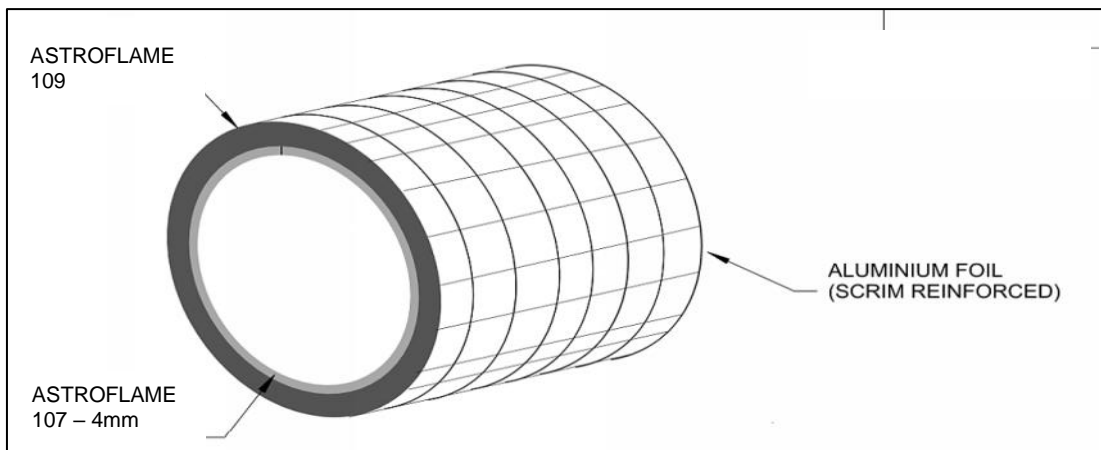

'Enhanced' Sleeve – 2 Layers of Astroflame 107

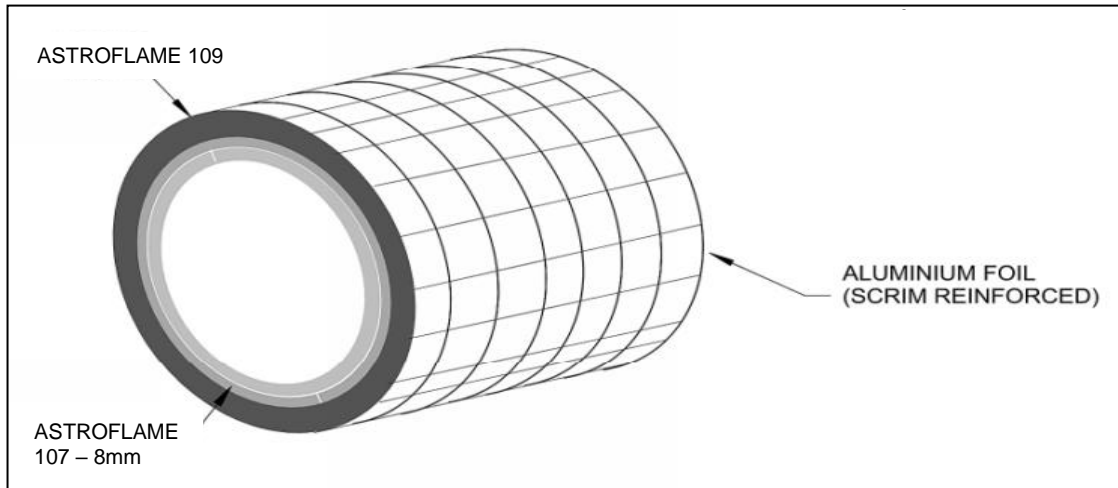

Astro Thermal Fire PS Fire Sleeve, Astro Thermal Fire PS+ Fire Sleeve and Astro DS+ Low Profile (LP) Duct Sleeve – Circular is available as single sleeve up to 500mm long which can be cut down to suit the intended application. It must be a minimum of 150mm long or longer if the wall is thicker. The Astro Thermal Fire PS Fire Sleeve, Astro Thermal Fire PS+ Fire Sleeve and Astro DS+ Low Profile (LP) Duct Sleeve is delivered in various sizes to fit particular pipe/duct diameters – see table below:

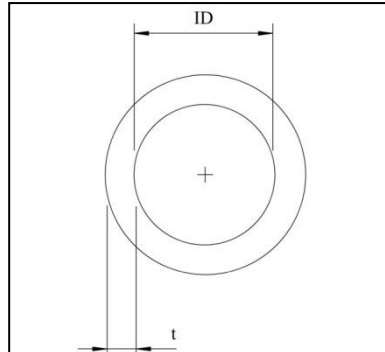

ID - Sleeve Size Inside Diameter (mm)	For Pipes with Nominal Outside Diameters (mm)	t - Thickness of Sleeve (mm) Nominal			Recommended Aperture Diameter (mm)		
		PS	PS+	DS+ (LP)	PS	PS+	DS+ (LP)
17*	15-19	25	29	14	67	75	55
21*	19-23	25	29	14	71	79	59
27*	25-29	25	29	14	77	85	65
34*	32-36	25	29	14	84	92	72
42*	40-44	25	29	14	92	100	80
48*	46-50	25	29	14	98	106	86
54*	52-56	25	29	14	104	112	92
60*	58-62	25	29	14	110	118	98
67*	65-69	25	29	14	117	125	105
76*	74-78	25	29	14	126	134	114
80*	78-82	25	29	14	130	138	118
89*	87-91	25	29	14	139	147	127
102*	100-104	25	29	14	152	160	140
103	100-103	-	-	14	-	-	134
108*	106-110	25	29	14	158	166	146
114*	112-116	25	29	14	164	172	152
127*	125-129	25	29	14	177	185	165
127	125-127	-	-	14	-	-	160
134*	132-136	25	29	-	184	192	-
140*	138-142	25	29	-	190	198	-
158	150-155	-	-	18**	-	-	200
159	157-161	25	29	-	209	217	-
160	158-162	25	29	-	210	218	-

* The Astro DS+ Low Profile (LP) Duct Sleeve is not currently manufactured in these sizes, however these sizes are permitted by the supporting test data and may be manufactured upon request** Astro DS+ Low Profile (LP) Duct Sleeve– Circular enhanced sleeve.

The Astro Thermal Fire PS Fire Sleeve, Astro Thermal Fire PS+ Fire Sleeve and Astro DS+ Low Profile (LP) Duct Sleeve - circular is installed inside the annular gap between pipe and aperture edge so that the outer edge of the wrap is flush with the wall/floor surface or protruding by up to 74mm on one or both sides of the supporting construction dependant on pipe size, material and type of wall or floor material.

If required for the purpose of smoke and draft stop, air or water tightness and airborne sound insulation, the gap between opening edge and pipe or wrap may be sealed off by Astro Intu Mastic. Astro Thermal Fire PS, Astro Thermal Fire PS+ and Astro DS+ Low Profile (LP) sleeves have been fire resistance tested both with and without Acrylic Intumescent sealant used around its external perimeter to seal any small gaps or imperfections between the sleeve and the wall or floor slab. Astro Intu Mastic may be used for this purpose provided it has evidence for use in similar applications and intended fire resistant durations.

For floor slab installations the Astro Thermal Fire PS and Astro Thermal Fire PS+ can be installed into square apertures of maximum size of 330mm x 330mm. The remaining aperture must then be filled to a minimum depth of 150mm with Astro FM Compound. This product is a non-combustible dimensionally stable gypsum mortars which would be classified A1.

See Annex B for which pipe sizes and materials this installation method applies. For a description of the installation procedure see Annexes B, C and D.

1.1.1.4 *Astro DS and Astro DS Duct Sleeves+ – Rectangular*

The Astro DS Duct Sleeve - rectangular is a flexible Intumescent material consisting primarily of mineral fibres intercalated graphite and organic binders and is formed into a rectangular pipe (duct) sleeve shape. It is grey/dark grey in colour with a glass fibre reinforced aluminium foil cladding around its perimeter for its full length. It has a nominal 25mm wall thickness. It may be cut down its length to aid fitment around the rectangular pipe (duct) service and a strip of aluminium foil tape used to seal over the joint.

The Astro DS Duct Sleeve+ – rectangular is as the Astro DS Duct Sleeve with the addition of further full length 4mm thick flexible Intumescent material located internally within the Astro DS Sleeve. The additional Intumescent is a 4mm thick Astroflame 107 flexible material consisting primarily of mineral fibres intercalated graphite and organic binders. It is grey in colour. It may be cut down its length to aid fitment around the pipe service and a strip of aluminium foil tape used to seal over the joint.

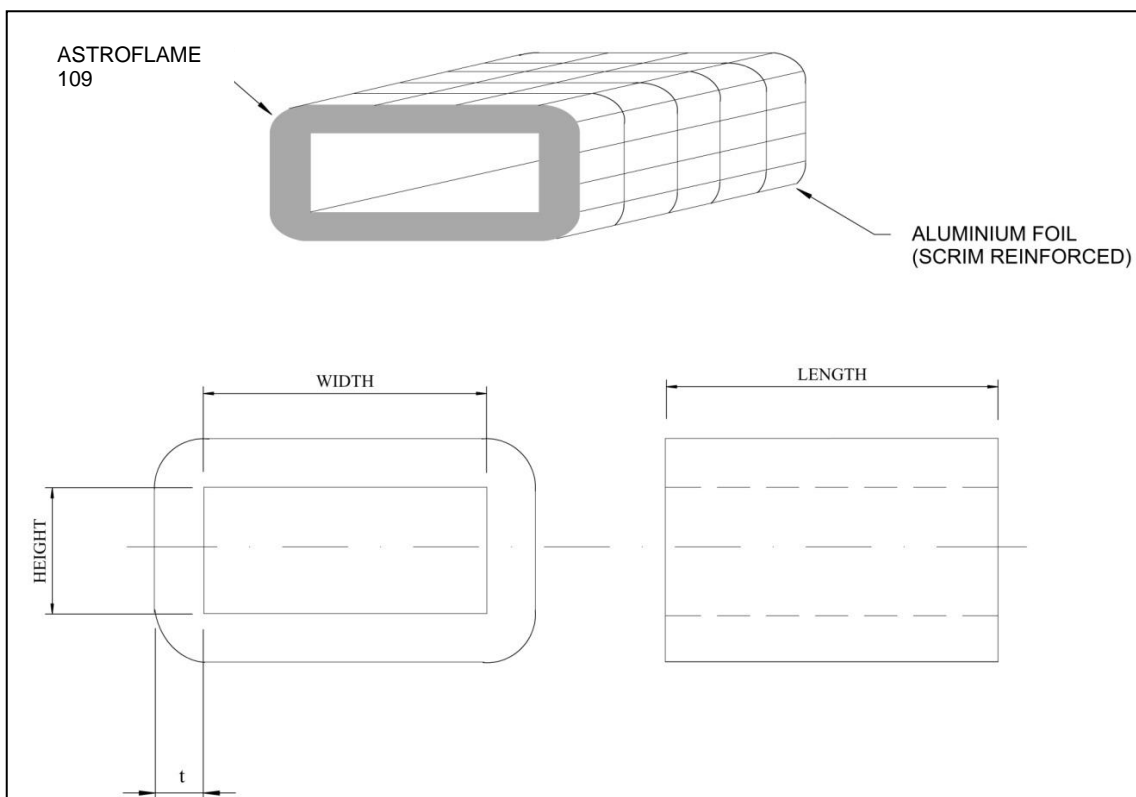

The Astro DS Duct Sleeve and Astro DS Duct Sleeve+ – Rectangular is available as single sleeve up to 500mm long which can be cut down to suit the intended application. It must be a minimum of 180mm long or longer if the supporting construction is thicker. The Astro DS Duct Sleeve and Astro DS Duct Sleeve+ is delivered in various sizes to fit particular duct sizes – see table below:

Wrap size (sleeve) inside size (mm)	For ventilation ducts with nominal outside diameters (mm)	Thickness of wrap (mm) nominal	Recommended aperture diameter (mm) width x height x (corner radius)
110 x 54	110 x 54	25mm	160 x 104 (25mm rad.)
234 x 29	234 x 29	25mm	284 x 79 (25mm rad.)
308 x 29	308 x 29	25mm	358 x 79 (25mm rad.)
204 x 60	204 x 60	25mm	254 x 110 (25mm rad.)

The Astro DS Duct Sleeve and Astro DS Duct Sleeve+ - rectangular is installed inside the annular gap between rectangular pipe (duct) and aperture edge so that the outer edge of the wrap is protruding by up to 24mm on one or both sides of the supporting construction wall dependant on rectangular pipe (duct) size, material and type of wall material.

If required for the purpose of smoke and draft stop, air or water tightness and airborne sound insulation, the gap between opening edge and pipe or wrap may be sealed off by a suitable acrylic Intumescent mastic construction sealant.

The Astro DS Duct Sleeve and Astro DS Duct Sleeve+ has been fire resistance tested both with and without Acrylic Intumescent sealant used around its external perimeter to seal any small gaps or imperfections between the sleeve and the wall. Astro Intu Mastic may be used for this purpose provided it has evidence for use in similar applications and intended fire resistant durations.

For a description of the installation procedure see Annexes B, C and D.

1.1.1.5 Astro DS+ Low Profile (LP) Duct Sleeves – Rectangular

The Astro DS+ Low Profile (LP) Duct Sleeve – rectangular is as the Astro DS Duct Sleeve+ with the thickness of the Astroflame 109 sleeve element reduced for use in specific circumstances. It is grey in colour. It may be cut down its length to aid fitment around the pipe (duct) service and a strip of aluminium foil tape used to seal over the joint.

The Astroflame 107 material may be installed at the top of the duct only (Standard Sleeve) or at the top and bottom of the duct (Enhanced Sleeve) as shown below:

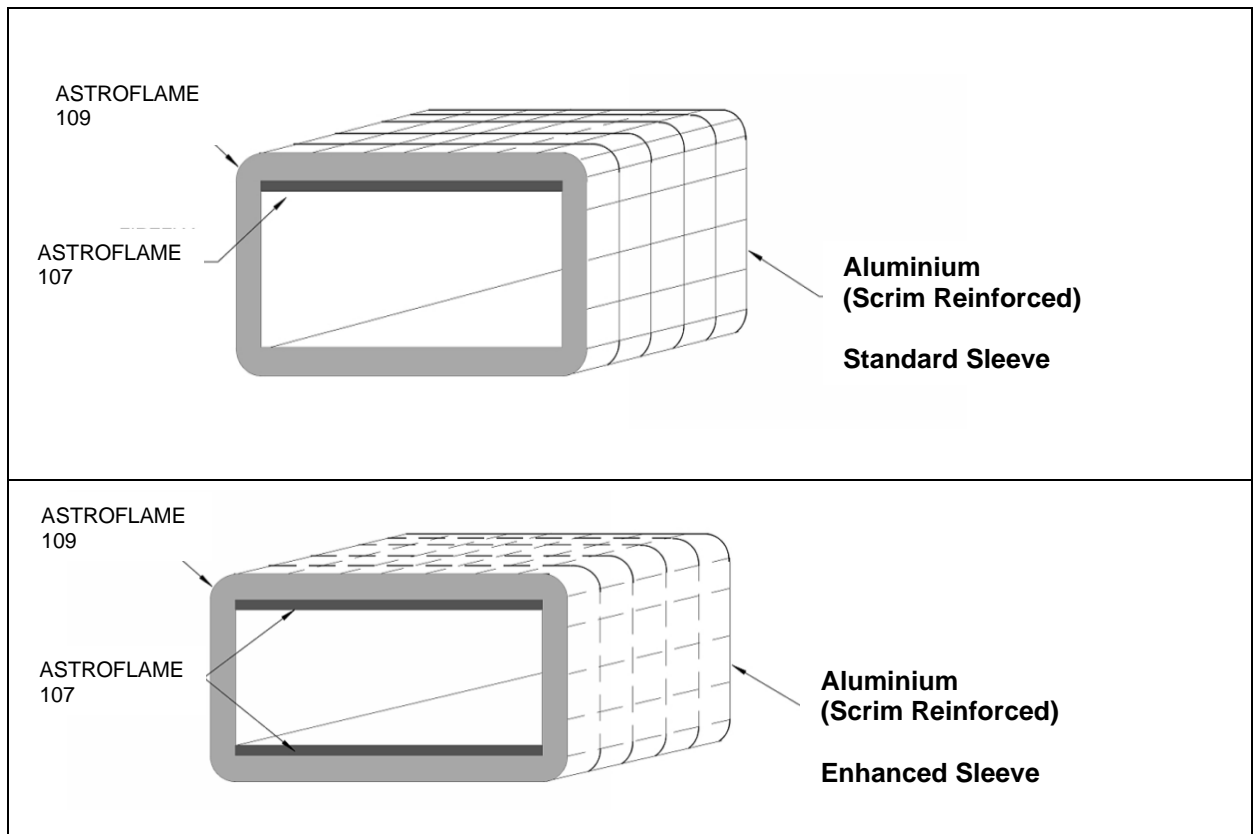

The Astro DS+ Low Profile (LP) Duct Sleeve – Rectangular is delivered in various sizes to fit particular duct sizes – see table below:

Wrap size (sleeve) inside size (mm)	For ventilation ducts with nominal outside diameters (mm)	Thickness of wrap (mm) nominal	Recommended aperture diameter (mm) width x height x (corner radius)
220 x 90	220 x 90	10 - 14mm	245 x 120 (10mm rad.)
204 x 60	204 x 60	10 - 14mm	225 x 85 (10mm rad.)
110 x 54	110 x 54	10 - 14 mm	135 x 80 (10mm rad.)

The Astro DS+ Low Profile (LP) Duct Sleeve - rectangular is installed inside the annular gap between rectangular pipe (duct) and aperture edge so that the outer edge of the sleeve/wrap is protruding by up to 25mm on both sides of the supporting construction wall dependant on rectangular pipe (duct) size, material and type of wall material.

If required for the purpose of smoke and draft stop, air or water tightness and airborne sound insulation, the gap between opening edge and pipe or wrap may be sealed off by a suitable acrylic Intumescent mastic construction sealant.

The Astro DS+ Low Profile (LP) Duct Sleeve has been fire resistance tested both with and without Acrylic Intumescent sealant used around its external perimeter to seal any small gaps or imperfections between the sleeve and the wall. Astro Intu Mastic may be used for this purpose provided it has evidence for use in similar applications and intended fire resistant durations.

For a description of the installation procedure see Annexes B, C and D.

2 Specification of the Intended Use in Accordance with the Applicable EAD

2.1 Intended Use

The intended use of Astro Thermal Fire PS Fire Sleeve; Astro Thermal Fire PS+ Fire Sleeve; Astro DS Duct Sleeve, Astro DS Duct Sleeve+ and Astro DS+ Low Profile (LP) Duct Sleeve is to reinstate the fire resistance performance of flexible wall constructions, rigid wall constructions and, for Astro Thermal Fire PS Fire Sleeve; Astro Thermal Fire PS+ Fire Sleeves only, rigid floor constructions; where they are penetrated by metal pipes, plastic pipes including PVC-U circular and rectangular ambient pressure extraction and ventilation 'duct' type pipes.

- (1) The specific elements of construction that Astro Thermal Fire PS Fire Sleeve; Astro Thermal Fire PS+ Fire Sleeve; Astro DS Duct Sleeve, Astro DS Duct Sleeve+ and Astro DS+ Low Profile (LP) Duct Sleeve may be used to provide a penetration seal in are as follows:

Flexible Walls:

The wall must have a minimum thickness of 132 mm and comprise timber or steel studs lined on both faces with minimum 2 layers of minimum 15mm thick lining boards (as shown in section 13.2.2 of EN 1366-3:2009).

- For 132 mm thick timber stud walls there must be a minimum distance of 100 mm of the seal to any stud and the cavity between stud and seal must be closed and minimum 100 mm insulation of Class A1 or A2 (in accordance with EN 13501-1) in the cavity between stud and seal.

For Astro DS+ Low Profile (LP) Duct Sleeve only; the wall must have a minimum thickness of 100 mm and comprise timber or steel studs lined on both faces with minimum 2 layers of minimum 12.5mm thick lining boards (as shown in section 13.2.2 of EN 1366-3:2009).

- For 100mm thick timber stud walls there must be a minimum distance of 100 mm of the seal to any stud and the cavity between stud and seal must be closed and minimum 50 mm insulation of Class A1 or A2 (in accordance with EN 13501-1) in the cavity between stud and seal.

Rigid Walls:

The wall must have a minimum thickness as given in Annex C and comprise concrete, aerated concrete or masonry, with a minimum density of 650 Kg/m³ (wall type A) or comprise concrete or masonry, with a minimum density of 1100 Kg/m³ (wall type B).

Rigid Floors:

The floor must have a minimum thickness as given in Annex C and comprise concrete with a minimum density of 2400 Kg/m³ (floor type A) or 550 Kg/m³ (floor type B), respectively.

The supporting construction must be classified in accordance with EN 13501-2 for the required fire resistance period.

This ETA does not cover use of this product as a penetration seal in sandwich panel constructions.

- (2) Astro Thermal Fire PS Fire Sleeve; Astro Thermal Fire PS+ Fire Sleeve; Astro DS Duct Sleeve, Astro DS Duct Sleeve+ and Astro DS+ Low Profile (LP) Duct Sleeve may be used to provide a penetration seal with the following specific services, single only:

HDPE pipes: for details on diameters and wall thickness Annex B, C and D.

PVC pipes: for details on diameters and wall thickness Annex B, C and D.

Metal pipes: for details on diameters, wall thickness and pipe materials see Annex B, C and D.

- (3) Apertures for the penetration of pipes require separation of minimum 200 mm.
- (4) Pipes protected by Astro Thermal Fire PS Fire Sleeve; Astro Thermal Fire PS+ Fire Sleeve; Astro DS Duct Sleeve and Astro DS Duct Sleeve+ shall be supported at maximum 150 mm away from both faces of flexible wall constructions and rigid wall constructions of Type A, maximum 150 mm away from both faces of rigid wall constructions of Type B and maximum 450 mm from the upper face of floor constructions.
- (5) Pipes protected by Astro DS+ Low Profile (LP) Duct Sleeve shall be supported at maximum 300 mm away from both faces of flexible wall constructions and rigid wall constructions of Type A and maximum 300 mm away from both faces of rigid wall constructions of Type B.

2.2 Working Life

The provisions made in this European Technical Assessment are based on an assumed working life of the Astro Thermal Fire PS Fire Sleeve, Astro Thermal Fire PS+ Fire Sleeve, Astro DS Duct Sleeve, Astro DS Duct Sleeve+ and Astro DS+ Low Profile (LP) Duct Sleeve of 10 years, provided that the conditions laid down in sections 4 and 5 for the packaging/transport/storage/installation/use/repair are met. The indications given on the working life cannot be interpreted as a guarantee given by the producer, but are to be regarded only as a means for choosing the right products in relation to the expected economically reasonable working life of the works.

2.3 Use Category

The use category of the Astro Thermal Fire PS Fire Sleeve and Astro DS Duct Sleeve, is Type **X**; the Astro Thermal Fire PS+ Fire Sleeve, Astro DS Duct Sleeve+ and Astro DS+ Low Profile (LP) Duct Sleeve is Type **Z₁**.

Type X:

Products intended for use in conditions exposed to weathering.

Type Y₁:

Products intended for use at temperatures below 0 °C with exposure to UV but no exposure to rain.

Type Y₂:

Products intended for use at temperatures between -5 °C and + 70°C, but with no exposure to rain nor UV.

Type Z₁:

Products intended for use at internal conditions with high humidity, excluding temperatures below 0°C.

Type Z₂:

Products intended for uses at internal conditions with humidity classes other than Z₁, excluding temperatures below 0°C.

A use category type at the top of the list is a higher requirement; therefore the requirements for any use category below are also fulfilled.

3 Performance of the Product and References to the Methods Used for its Assessment

BWR	Characteristic	Assessment of Characteristic
2	Safety in Case of Fire	
	Reaction to Fire	See ETA Section 4.1.1 Class E – EN 13501-1: 2007
	Resistance to Fire	See ETA Section 4.1.2
3	Hygiene, Health & the Environment	
	Release of Dangerous Substances	See ETA Section 4.2.1
-	General Aspects Related to the Performance of the Product	
	Durability & Serviceability	See ETA Section 4.3.1 Astro Thermal Fire PS Fire Sleeve and Astro DS Duct Sleeve = Type X Astro Thermal Fire PS+ Fire Sleeve, Astro DS Duct Sleeve+ and Astro DS+ Low Profile (LP) Duct Sleeve = Type Z₁

4 Methods of Verification

4.1 Safety in Case of Fire

4.1.1 Reaction to Fire

The component parts of Astro Thermal Fire PS Fire Sleeve, Astro Thermal Fire PS+ Fire Sleeve, Astro DS Duct Sleeve, Astro DS Duct Sleeve+ and Astro DS+ Low Profile (LP) Duct Sleeve are classified 'E' in accordance with EN 13501-1 for wall or floor applications.

4.1.2 Resistance to Fire

Astro Thermal Fire PS Fire Sleeve, Astro Thermal Fire PS+ Fire Sleeve, Astro DS Duct Sleeve, Astro DS Duct Sleeve+ and Astro DS+ Low Profile (LP) Duct Sleeve have been tested in accordance with EN 1366-3:2006 and EN 1366-3:2009, installed within apertures in flexible walls (drywalls), rigid walls (aerated concrete blocks) and low density concrete floors.

For details of classification for metal and plastic pipes covered see Annex B, C and D.

The seals may only be penetrated by the services listed in Annex B, C and D. Other parts or support constructions must not penetrate the seal.

For details of suitable wall and floor constructions see 1.2.1 and Annex B, C and D.

Note – The supporting construction must be classified in accordance with EN 13501-2 for the required fire resistance period.

4.1.2.1 General

The following conditions apply to seals within any of the above constructions:

The service support construction must be fixed to the building element containing the penetration seal or a suitable adjacent building element, on both sides of the penetration in such a manner that in the case of fire, no additional load is imposed on the seal. Furthermore it is assumed that this support is maintained for the required period of fire resistance.

Specific considerations:

- Approval is for service installation in non-load bearing elements of construction only
- Pipes must be perpendicular to the seal surface.
- It is assumed that compressed air systems are switched off by other means in the case of fire.
- The function of the pipe seal in case of pneumatic dispatch systems, pressurised air systems etc. is guaranteed only when the systems are shut off in case of fire.
- The ETA does not address any risks associated with leakage of dangerous liquids or gases caused by failure of the pipe(s) in case of fire.
- The durability assessment does not take account of the possible effect of substances permeating through the pipe on the penetration seal.
- Other parts or supporting construction shall not penetrate the seal.
- The classifications for Astro Thermal Fire PS Fire Sleeves relate to U/C (capped outside the furnace/uncapped inside)
- The classifications for Astro Thermal Fire PS+ Fire Sleeves relate to U/U applications (uncapped outside the furnace/uncapped inside).
- The classifications for Astro DS Duct Sleeve, Astro DS Duct Sleeve+ and Astro DS+ Low Profile (LP) Duct Sleeve relate to U/U applications (uncapped outside the furnace/uncapped inside).

For further information refer to annex B, C and D and national regulations.

4.2 Hygiene, Health and the Environment

4.2.1 Release of Dangerous Substances

The Manufacturer has provided a Material Safety Data Sheet according to Regulation 1907/2006/EC and a declaration that Astro Thermal Fire PS Fire Sleeve, Astro Thermal Fire PS+ Fire Sleeve, Astro DS Duct Sleeve, Astro DS Duct Sleeve+ and Astro DS+ Low Profile (LP) Duct Sleeve are in compliance with Regulation 1907/2006/EC concerning the Registration, Evaluation, Authorisation and Restriction of Chemicals (REACH).

Confirmation has further been declared that toxic, carcinogenic, toxic for reproduction and mutagenic chemical substances of category 1 and 2 ≥ 0.1 % are not used for Astro Thermal Fire PS Fire Sleeve, Astro Thermal Fire PS+ Fire Sleeve, Astro DS Duct Sleeve, Astro DS Duct Sleeve+ and Astro DS+ Low Profile (LP) Duct Sleeve and that all other dangerous chemical substances have been considered for the classification of the products according to the Regulation 1272/2008/EC (classification, labelling and packaging of substances and mixtures, including amendments).

In addition to the specific clauses relating to dangerous substances contained in this European Technical Assessment, there may be other requirements applicable to the products falling within its scope (e.g. transposed European legislation and national laws,

regulations and administrative provisions). In order to meet the provisions of the Construction Products Regulation, these requirements need also to be complied with, when and where they apply.

4.3 General Aspects Related to the Performance of the Product

4.3.1 Durability

Astro Thermal Fire PS Fire Sleeve, Astro Thermal Fire PS+ Fire Sleeve, Astro DS Duct Sleeve, Astro DS Duct Sleeve+ and Astro DS+ Low Profile (LP) Duct Sleeve component materials have been tested to determine their use category and the results of the tests have demonstrated:

- Astro Thermal Fire PS Fire Sleeve and Astro DS Duct Sleeve have a use category of X - suitability for penetration seals intended for use being used in conditions exposed to weathering.
- Astro Thermal Fire PS+ Fire Sleeve, Astro DS Duct Sleeve+ have a use category of Z1 - suitability for penetration seals intended for use at internal conditions with high humidity, excluding temperatures below 0°C).
- Astro DS+ Low Profile (LP) Duct Sleeve have a use category of Z1 - suitability for penetration seals intended for use at internal conditions with high humidity, excluding temperatures below 0°C).

5 Installation

This ETA is issued under the assumption that the installation of the approved product shall be in accordance with the manufacturer's technical product literature and installation instructions.

The manufacturer's technical product literature and installation instructions are given in Annex E.

6 Packaging, Transport and Storage

The manufacturer shall provide information regarding correct transport and storage in the accompanying documentation and/or on the packaging of the product.

The following shall be indicated as minimum: storage temperature, type of storage, maximum duration of storage and required data related to minimum temperature for transport and storage.

The manufacturer's technical product literature and installation instructions can be found in Annex E.

7 Use, Maintenance & Repair

Astro Thermal Fire PS Fire Sleeve, Astro Thermal Fire PS+ Fire Sleeve, Astro DS Duct Sleeve, Astro DS Duct Sleeve+ and Astro DS+ Low Profile (LP) Duct Sleeves should be installed and used as described earlier in this document.

The assessment of the fitness for use is based on the assumption that damage, for example caused by accidental impact, would mean the product is replaced. The relevant manufacturer instructions shall be followed.

The manufacturer's technical product literature and installation instructions can be found in Annex E.

8 Assessment & Verification of Constancy of Performance

8.1 AVCP System

According to Decision 1999/454/EC of the European Commission the system(s) of Assessment and Verification of Constancy of Performance (see Annex V of Regulation (EU) No. 305/2011) given in Table 1 applies.

Table 1: System of Assessment and Verification of Constancy of Performance

Product	Intended Use	AVCP System
Astro Thermal Fire PS Fire Sleeve, Astro Thermal Fire PS+ Fire Sleeve, Astro DS Duct Sleeve, Astro DS Duct Sleeve+ and Astro DS+ Low Profile (LP) Duct Sleeve	Fire Stopping & Sealing Product	1

The System of Attestation and Verification of Constancy of Performance referred to above is defined as follows:

System 1: Certification of the Conformity of the product by a Notified Certification Body on the basis of Annex V of Regulation (EU) No. 305/2011.

9 Technical Details necessary for the Implementation of the AVCP System, as foreseen in the applicable EAD

9.1 Tasks for the Manufacturer

9.1.1 Factory Production Control (FPC)

The manufacturer has a Factory Production Control System (FPC) and exercises permanent internal control of production. All the elements, requirements and provisions adopted by the manufacturer are documented in a systematic manner in the form of policies, procedures and work instructions. This FPC system ensures that the product is in conformity with this European Technical Assessment.

The manufacturer shall only use raw materials or components that are supplied with the relevant inspection documents as laid down in the Control Plan¹. All incoming raw materials shall be subject to inspection, verification, controls and tests (as applicable) by the manufacturer.

The Control Plan, Reference BMT001, which is part of the technical documentation of this European Technical Assessment includes details of the extent, nature and frequency of testing and controls to be performed within the FPC system and has been agreed between the ETA holder and Element Materials Technology Rotterdam B.V. Any changes to the FPC; Control Plan or the Product shall only be made following approval by Element Materials Technology Rotterdam B.V.

The results of FPC are recorded and evaluated. These records include but are not limited to:

- Product specification and designation, basic materials and components
- Type(s) of Control testing

¹ The Control Plan has been deposited at Element Materials Technology Rotterdam B.V. and is only made available to the Approved Bodies involved in the AVCP procedure.

- Date of manufacture of the product and date of testing of the product or basic material and components;
- Result of control and testing and, if appropriate, comparison with requirements;
- Signature of the person responsible for FPC

The manufacturer shall, on the basis of a contract, involve a body (bodies) which is (are) approved for the tasks referred to in section 9.1.1 of this ETA. For this purpose, the "control plan" referred to in sections 9.1.1 and 9.2.2 shall be handed over by the manufacturer to the approved body or bodies involved.

9.1.2 Technical Data Sheet

9.1.2.1 Field of Application

- Building elements for which the penetration seal is suitable, type and properties of the building elements like minimum thickness, density and, in case of lightweight constructions, the construction requirements.
- Services for which the penetration seal is suitable, type and properties of the services; including material, diameter, thickness etc. In the case of pipes including insulation materials; details of necessary/allowed supports/fixings.
- Construction of the penetration seal including the necessary components and additional products e.g. backing materials with clear indication whether they are generic or specific.

9.1.2.2 Installation Instructions

The installation instructions shall include the following as minimum:

- Steps to be followed for installation
- Procedure in case of retrofitting
- Stipulations on maintenance, repair and replacement

9.2 Tasks of Notified Bodies

9.2.1 Initial Type Testing of the Product

For initial type-testing the results of the tests performed as part of the assessment for the European Technical Assessment shall be used unless there are changes in the production line or plant. In such cases the necessary type testing has to be agreed between Element Materials Technology Rotterdam B.V. and the Notified Body.

9.2.2 Initial Inspection of Factory and of Factory Production Control

The Notified Body shall ascertain that, in accordance with the provisions laid down in the Control Plan, Reference BMT001, the factory and the factory production control are suitable to ensure continuous and orderly manufacturing of the product according to the specifications mentioned in Section 2, as well as to the Annexes to this European Technical Assessment.

9.2.3 Continuous Surveillance

The Notified Body shall visit the factory twice a year for regular inspection. It shall be verified that the system of factory production control and the specified manufacturing process is maintained in accordance with the provisions of this European Technical Assessment and the Control Plan.

Continuous surveillance and assessment of factory production control shall be performed in accordance with the provisions laid down in the agreed Control Plan.

The results of product certification and continuous surveillance shall be made available on demand by the certification or inspection body or to Element Materials Technology Rotterdam B.V. In cases where the provisions of this European Technical Assessment and the prescribed Control Plan are no longer fulfilled, the conformity certificate shall be withdrawn and the relevant authority/ies shall be informed.

Important:

This European Technical Assessment is issued for Astro Thermal Fire PS Fire Sleeve, Astro Thermal Fire PS+ Fire Sleeve, Astro DS Duct Sleeve, Astro DS Duct Sleeve+ and Astro DS+ Low Profile (LP) Duct Sleeves on the basis of agreed data/information deposited with Element Materials Technology Rotterdam B.V. which identifies the product that has been assessed and judged. Element Materials Technology Rotterdam B.V. shall be notified of changes to the product or production process which could result in the deposited data/information being incorrect before introduction of such changes. Element Materials Technology Rotterdam B.V. will evaluate whether or not the proposed changes will have an effect on the ETA and consequently the validity of the CE certification and if further assessment and/or amendment of the ETA will be necessary.

Issued in Amsterdam, Netherlands on 07/01/2021

By

A handwritten signature in black ink, appearing to read 'Nires D Somlie', with a long horizontal flourish underneath.

Nires D Somlie

Technical Assessment Body Manager

10 Annex A: Reference Documents

A.1 References to Standards mentioned in the ETA:

EN 1366-3: 2009	Fire resistance tests for service installations - Part 3: Penetration seals
EN 13501-1	Fire classification of construction products and building elements - Part 1: Classification using test data from reaction to fire tests
EN 13501-2	Fire classification of construction products and building elements – Part 2: Classification using test data from fire resistance tests
ISO 9001	Quality Management Systems - Requirements

A.2 Other Reference Documents

EOTA TR 024	Characterisation, Aspects of Durability and Factory Production Control for Reactive Materials, Components and Products
-------------	--

ANNEX B: RESISTANCE TO FIRE CLASSIFICATION

Contents

Section

- B Astro Thermal Fire PS Fire Sleeve and Astro DS Duct Sleeve coverage**
- B.1 Field of application for Astro Thermal Fire PS Fire Sleeve – Circular for metal pipes” penetrating flexible or rigid fire resistant walls for applications up to EI120:**
- B.1.2 Graph showing the coverage of the allowable “metal” pipe diameter and wall thickness for applications up to EI120
- B.1.3 Graph showing the coverage of the allowable “metal” pipe diameters and wall thickness for applications up to E120 and EI30
- B.2 Field of application for Astro Thermal Fire PS Fire Sleeve – Circular or PVC-U (according to EN 1329-1)* and HDPE (according to EN 1519-)* pipes penetrating fire resistant walls for applications up to EI120:**
- B.2.1 Graph showing the coverage of the allowable PVC-U pipe diameters and wall thickness for applications up to EI120
- B.2.2 Graph showing the coverage of the allowable HDPE pipe diameters and wall thickness for applications up to EI120
- B.2.3 Graph showing the coverage of the allowable HDPE pipe diameters and wall thickness for applications up to EI90
- B.3 Field of application for Astro Thermal Fire PS Fire Sleeve - Circular for PVC-U (according to EN 1329-1)* pipes penetrating fire resistant walls for applications up to EI240:**
- B.3.1 Graph showing the coverage of the allowable PVC pipe diameters and wall thickness for applications up to EI240
- B.4 Field of application for Astro DS Duct Sleeve – Rectangular. For PVC-U rectangular ambient pressure extraction and ventilation ‘duct’ type pipes penetrating fire resistant walls for applications up to EI120:**
- B.4.1 The table showing the coverage of the allowable PVC-U rectangular ambient pressure extraction and ventilation ‘duct’ type pipes and wall thickness for applications up to EI120
- B.5 Field of application for Astro DS Duct Sleeve – Rectangular for use with a 200mm wide x 60mm high PVC-U rectangular ambient pressure extraction and ventilation ‘duct’ type pipes penetrating fire resistant masonry walls for applications up to EI240:**
- B.6 Field of application for Astro Thermal Fire PS Fire Sleeve – Circular for PVC-U (according to EN 1329-1)* pipes penetrating fire resistant floors for applications up to EI120**

** In Germany, the PVC-U pipes have to comply additionally to DIN 8062 & HDPE pipes additionally to DIN 8074.*

- B.6.1 Graph showing the coverage of the allowable PVC-U (according to EN 1329-1) pipe diameters and wall thickness for applications up to EI120
- B.7 Field of application for Astro Thermal Fire PS Fire Sleeve – Circular for PVC-U (according to EN 1329-1)* and HDPE (according to EN 1519-1)* pipes penetrating fire resistant floors for applications up to EI120**
- B.7.1 Graph showing the coverage of the allowable PVC-U (according to EN 1329-1) pipe diameters and wall thickness for applications up to EI120.
- B.7.2 Graph showing the coverage of the allowable HDPE (according to EN 1329-1) pipe diameters and wall thickness for applications up to EI120.
- B.8 Field of application for Astro Thermal Fire PS Fire Sleeve in conjunction with fire stopping compound – Circular for PVC-U according to EN 1329-1)* and HDPE (according to EN 1519-1)* pipes penetrating fire resistant floors for applications up to EI120**
- B.8.1 Graph showing the coverage of the allowable PVC-U (according to EN 1329-1) pipe diameters and wall thickness for applications up to EI90
- B.8.2 Graph showing the coverage of the allowable PVC-U (according to EN 1329-1) pipe diameters and wall thickness for applications up to EI120
- B.8.3 Graph showing the coverage of the allowable HDPE U (according to EN 1519-1) pipe diameters and wall thickness for applications up to EI120

** In Germany, the PVC-U pipes have to comply additionally to DIN 8062 & HDPE pipes additionally to DIN 8074.*

B Astro Thermal Fire PS Fire Sleeve coverage

B.1 Field of application for Astro Thermal Fire PS Fire Sleeve – Circular for “metal pipes” penetrating flexible or rigid fire resistant walls for applications up to EI120:

The pipe may be fitted within both flexible and rigid walls constructed in accordance with section 1.2.1 of this ETA with a minimum 132mm thickness. For flexible walls using steel stud the wall can be constructed with or without cavity insulation

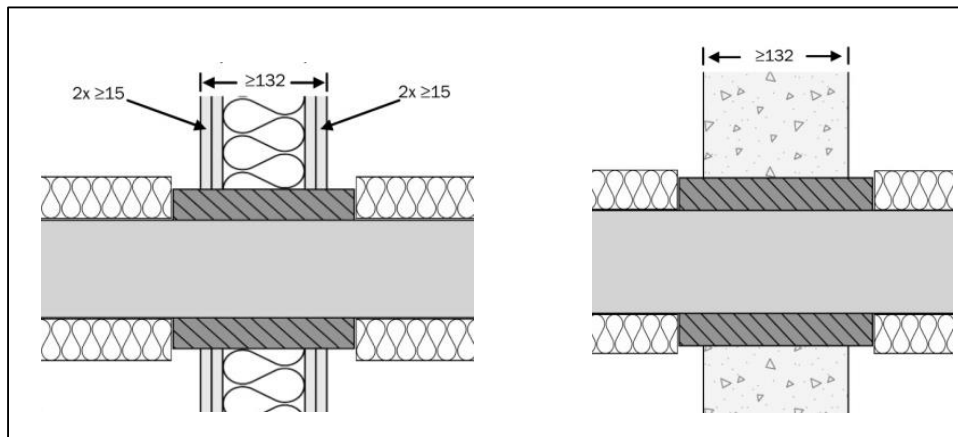

The seal must be a minimum of 150mm long with 9mm protruding each side of the wall

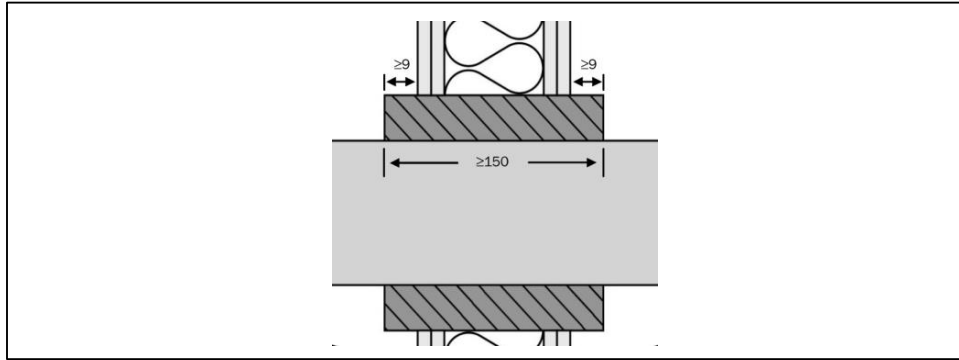

- If the wall is thicker than 132mm the seal must be longer to maintain the 9mm protruding from each face
- The seal must be friction fitted within an aperture nominally 50mm larger than the outside diameter of the pipe
- The pipe must be fitted with a minimum 40mm thickness of continuous stonewool pipe insulation product ref. Rockwool Rocklap H&V pipe section of density 120kg/m³ (of class A1 or A2 according to EN 13501-1) butted up to the Fire Sleeve
- A support must be provided each side of the wall a maximum of 150mm from the surface of the wall
- All metal pipe materials are covered which have a thermal conductivity equal or lower than copper provide the melting point is at least equal or greater. This allows the use of copper, cast iron, stainless steel and mild steel pipes
- All pipe end configurations U/C, C/C are covered for use
- Intumescent acrylic mastic may be used in addition to seal between the Astro Thermal Fire PS Fire Sleeve and the wall if required
- Pipe penetration seals must be fitted a minimum of 200mm apart

B.1.2 The line graph below shows the coverage of the allowable “metal” pipe diameter and wall thickness for applications up to EI120
(any pipe size variation along the line is covered)

Metal pipes fitted with minimum 150mm long Astro Thermal Fire PS Fire Sleeve and 40mm thick continuous rock fibre pipe insulation penetrating 132mm minimum thickness flexible or rigid walls

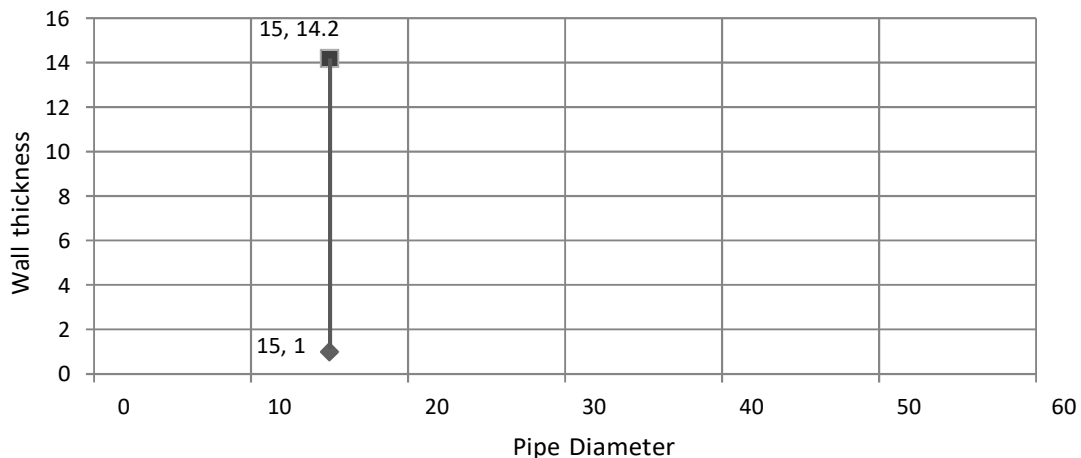

B.1.3 The area inside the graph below shows the coverage of the allowable “metal” pipe diameters and wall thickness for applications up to E120 and EI30:

Metal pipes fitted with minimum 150mm long Astro Thermal Fire PS Fire Sleeve and 40mm thick continuous rock fibre pipe insulation penetrating 132mm minimum thickness flexible or rigid walls

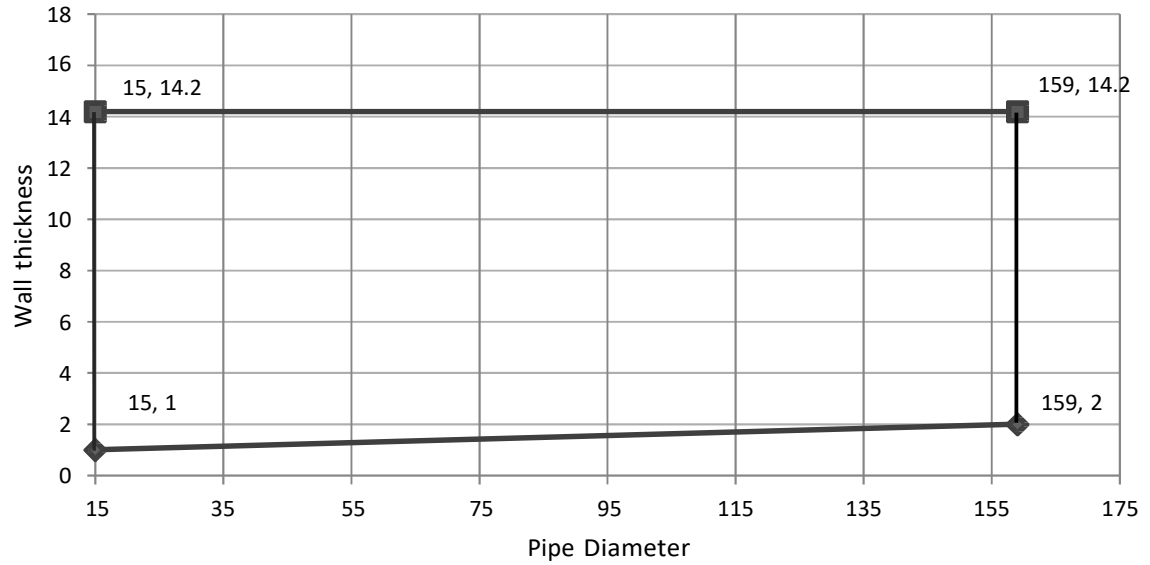

B.2 Field of application for Astro Thermal Fire PS Fire Sleeve – Circular for PVC-U (according to EN 1329-1)* and HDPE (according to EN 1519-1)* pipes penetrating fire resistant walls for applications up to EI120:

The pipe may be fitted within both flexible and rigid walls constructed in accordance with section 1.2.1 of this ETA with a minimum 132mm thickness. For flexible walls using steel stud the wall can be constructed with or without cavity insulation

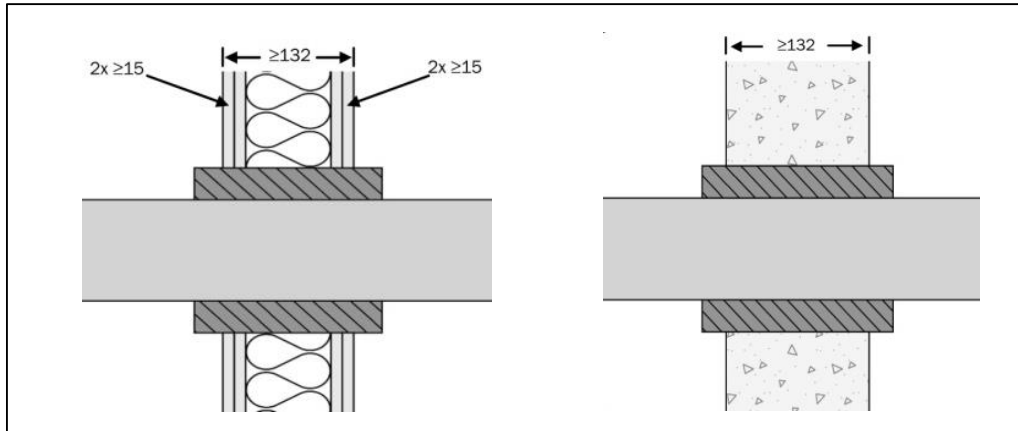

The seal must be a minimum of 180mm long with 24mm protruding each side of the wall

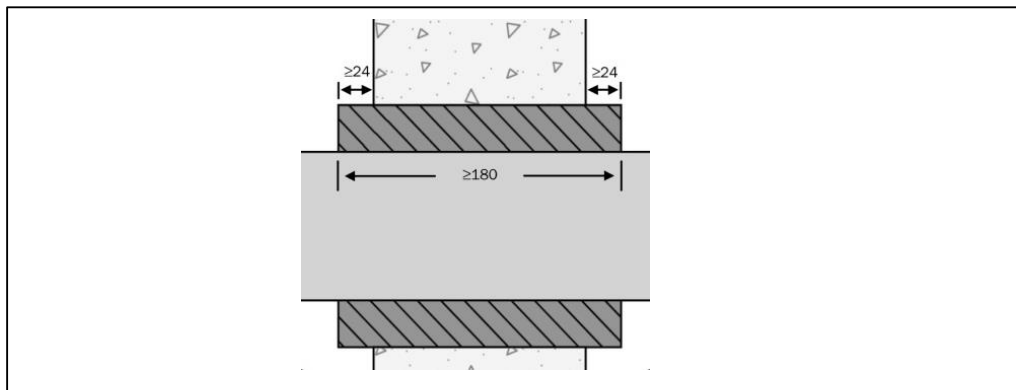

- If the wall is thicker than 132mm the seal must be longer to maintain the 24mm protruding from each face
- The seal must be friction fitted within an aperture nominally 50mm larger than the outside diameter of the pipe
- For flexible walls constructed with steel studs then the wall can be fitted with or without cavity insulation
- A support must be provided each side of the wall a maximum of 150mm from the surface of the wall
- Pipe end configurations U/C, C/C are covered for use
- Intumescent acrylic mastic may be used in addition to seal between the Astro

* In Germany the PVC-U Fire PS Fire Sleeve may additionally be used for HDPE pipes additionally to DIN 8074. Pipe penetration seals must be fitted a minimum of 200mm apart

B.2.1 The line graphs below show the coverage of the allowable PVC-U (according to EN 1329-1)* pipe diameters and wall thickness for applications up to EI120: (any pipe size variation along the lines and the area between the lines is covered)

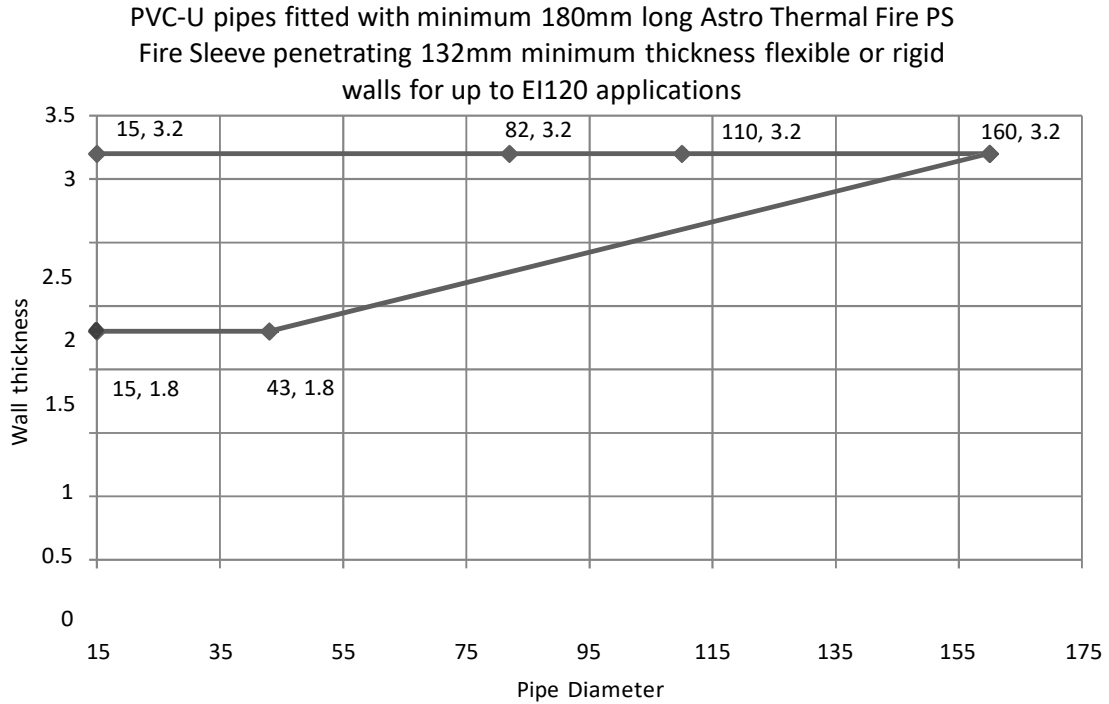

B.2.2 The line graphs below show the coverage of the allowable HDPE (according to EN 1519-1)* pipe diameters and wall thickness for applications up to EI120: (any pipe size variation along the lines and the area between the lines is covered)

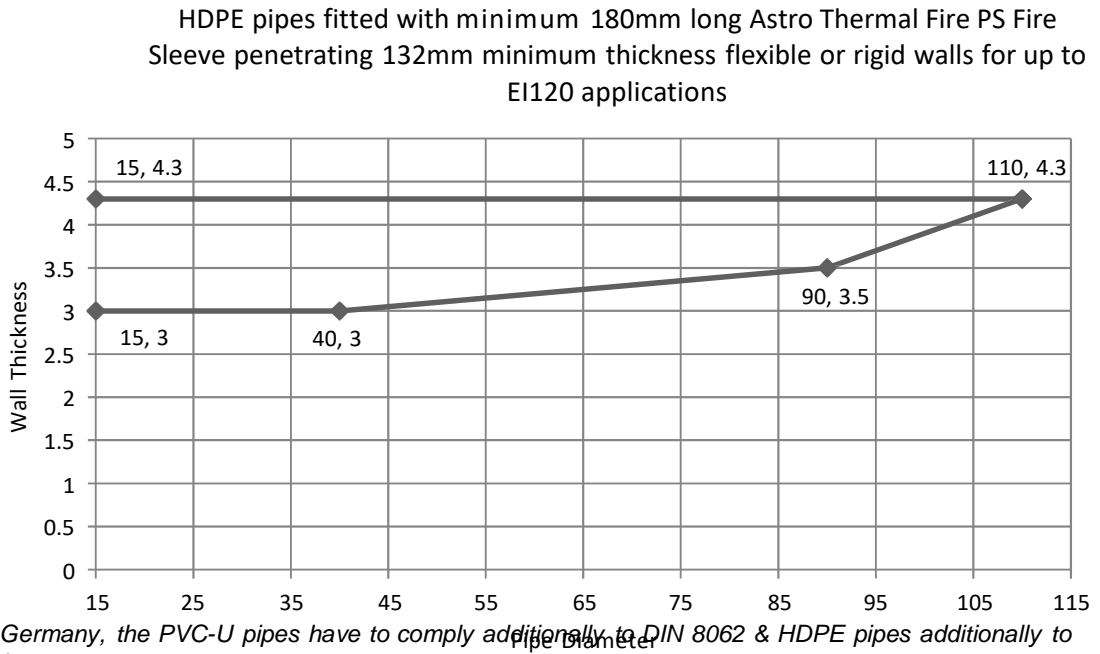

* In Germany, the PVC-U pipes have to comply additionally to DIN 8062 & HDPE pipes additionally to DIN 8074.

B.2.3 The line graph below shows the coverage of the allowable HDPE (according to EN 1519-1)* pipe diameters and wall thickness for applications up to EI90: (any pipe size variation along the lines and the area between the lines is covered)

HDPE pipes fitted with minimum 180mm long Astro Thermal Fire PS Fire Sleeve penetrating 132mm minimum thickness flexible or rigid walls for up to EI90 applications

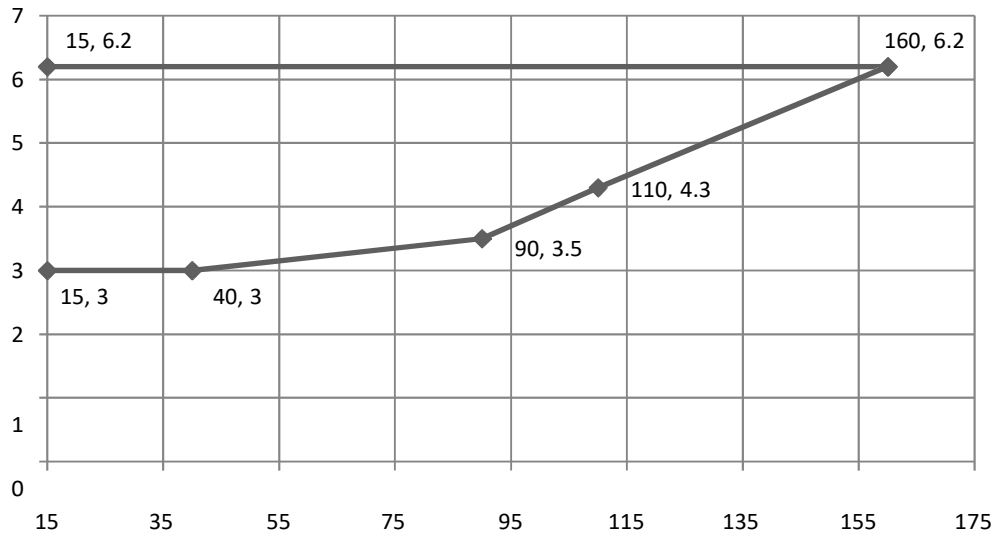

B.3 Field of application for Astro Thermal Fire PS Fire Sleeve - Circular for PVC-U (according to EN 1329-1)* pipes penetrating fire resistant walls for applications up to EI240:

- An Astro Thermal Fire PS Fire Sleeve may be used on pipes up to 110mm diameter x 3mm thick PVC pipe provided the follow criteria are meet:
- The pipe may only be fitted within a rigid wall constructed in accordance with section 1.2.1 of this ETA with a minimum 150mm thickness.
- The seal must be a minimum of 150mm long finishing flush with each side of the wall
- The seal must be friction fitted within an aperture nominally 50mm large than the external pipe diameter
- A support must be provided each side of the wall a maximum of 150mm from the surface of the wall
- Only 3mm wall thickness pipe is used
- Pipe penetration seals must be fitted a minimum of 200mm apart
- Pipe end configurations U/C, C/C are covered for use.

* In Germany, the PVC-U pipes have to comply additionally to DIN 8062 & HDPE pipes additionally to DIN 8074.

B.3.1 The line graph below shows the coverage of the allowable PVC (according to EN 1329-1)* pipe diameters and wall thickness for applications up to EI240: (any pipe size variation along the line is covered)

PVC-U pipes fitted with minimum 150mm long Astro Thermal Fire PS Fire Sleeve penetrating 150mm minimum thickness rigid walls for up to EI240 applications

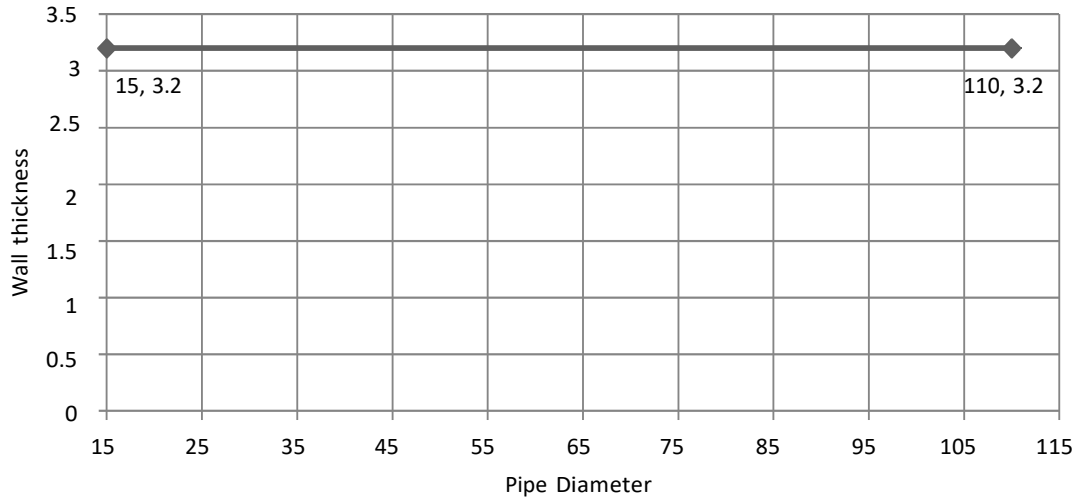

B.4 Field of application for Astro DS Duct Sleeve – Rectangular. For PVC-U rectangular ambient pressure extraction and ventilation ‘duct’ type pipes penetrating fire resistant walls for applications up to EI120:

The duct may be fitted within both flexible and rigid walls constructed in accordance with section 1.2.1 with a minimum 132mm thickness. For flexible walls using steel stud the wall can be constructed with or without cavity insulation

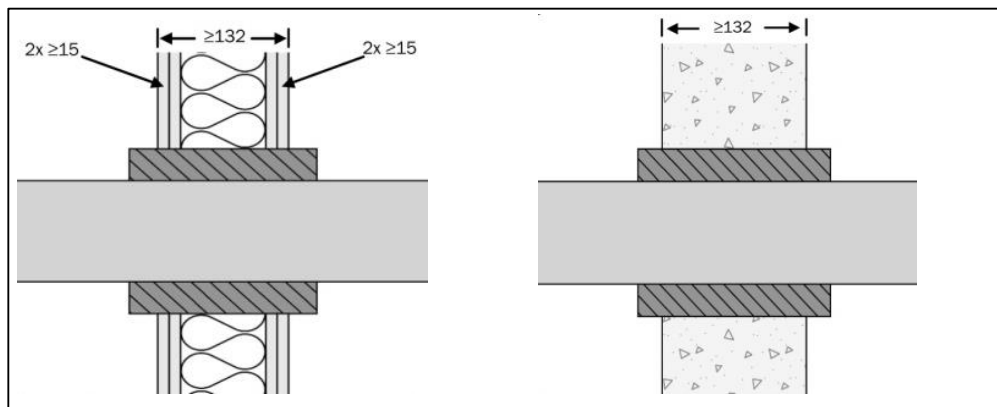

The seal must be a minimum of 180mm long with 24mm protruding each side of the wall

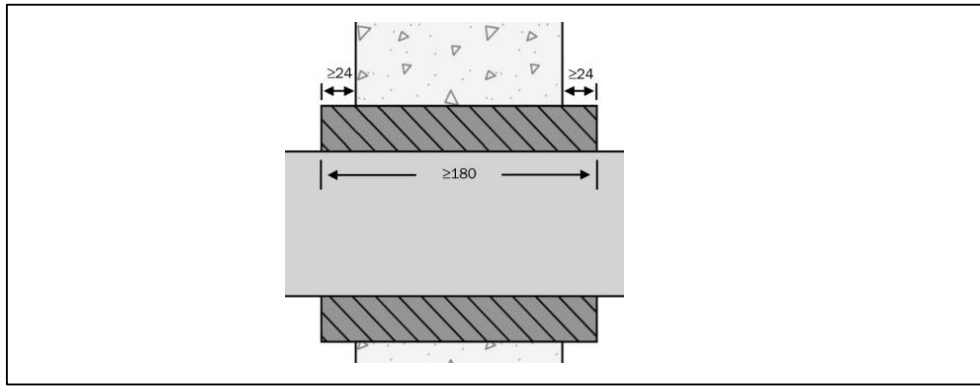

- If the wall is thicker than 132mm the seal must be longer to maintain the 24mm protruding from each face
- The seal must be friction fitted within an aperture nominally 50mm larger than the external dimensions of the rectangular pipe (duct)
- For flexible walls constructed with steel studs then the wall can be fitted with or without cavity insulation
- A support must be provided each side of the wall a maximum of 150mm from the surface of the wall
- All pipe end configurations U/U C/U, U/C, C/C are covered for use
- Intumescent acrylic mastic may be used in addition to seal between the Astro DS Duct Sleeve and the wall if required
- Pipe penetration seals must be fitted a minimum of 200mm apart.

B.4.1 The Table below shows the coverage of the allowable PVC-U rectangular ambient pressure extraction and ventilation ‘duct’ type pipes and wall thickness for applications up to EI120

The PVC-U rectangular duct sizes that may be used in conjunction with the Astro DS Duct Sleeve - rectangular are:

PVC-U Rectangular Pipe (duct) Size	Nominal Wall Thickness
110mm wide x 54mm high	1.5-1.7mm
204mm wide x 60mm high	1.5-1.7mm
310mm wide x 29mm high	1.8-2.0mm

B.5 Field of application for Astro DS Duct Sleeve – Rectangular for use with a 200mm wide x 60mm high PVC-U rectangular ambient pressure extraction and ventilation ‘duct’ type pipes penetrating fire resistant masonry walls for applications up to EI240:

An Astro DS Duct Sleeve may be used on a 200mm wide x 60mm high x 1.5 - 1.7mm wall thickness PVC-U rectangular pipe (duct) provided the following criteria are met:

- The pipe may only be fitted within a rigid wall constructed in accordance with section 1.2.1 of this ETA with a minimum 150mm thickness
- The seal must be a minimum of 180mm long with 15mm protruding each side of the wall

** In Germany, the PVC-U pipes have to comply additionally to DIN 8062 & HDPE pipes additionally to DIN 8074.*

- The seal must be friction fitted within an aperture nominally 50mm larger the external pipe size.
- A support must be provided each side of the wall a maximum of 150mm from the surface of the wall
- Intumescent acrylic mastic may be used in addition to seal between the Astro DS Duct Sleeve and the wall if required
- Pipe penetration seals must be fitted a minimum of 200mm apart
- Pipe end configurations U/C, C/C are covered for use.

B.6 Field of application for Astro Thermal Fire PS Fire Sleeve – Circular for PVC-U (according to EN 1329-1)* pipes penetrating fire resistant floors for applications up to EI120:

The pipe may be fitted within rigid floors constructed in accordance with section 1.2.1 of this ETA with a minimum 150mm thickness.

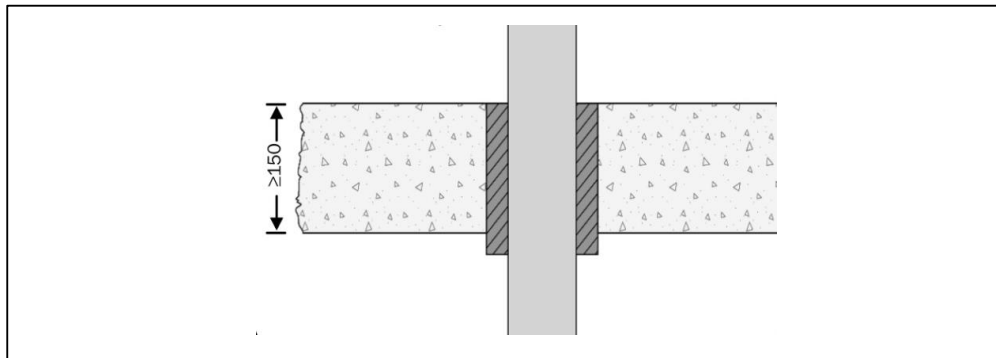

- The seal must be a minimum of 175mm long with 25mm protruding below the underside of the floor slab
- The seal must be friction fitted within an aperture nominally 50mm larger than the outside diameter of the pipe
- A support must be provided above the floor a maximum of 450mm from the surface of the floor
- Pipe end configurations U/C, C/C are covered for use
- Intumescent acrylic mastic may be used in addition to seal between the Astro Thermal Fire PS Fire Sleeve and the wall if required
- Pipe penetration seals must be fitted a minimum of 200mm apart.

* In Germany, the PVC-U pipes have to comply additionally to DIN 8062 & HDPE pipes additionally to DIN 8074.

B.6.1 The line graph below shows the coverage of the allowable PVC-U (according to EN 1329-1)* pipe diameters and wall thickness for applications up to EI120: (any pipe size variation along the line is covered)

PVC-U pipes fitted with minimum 175mm long Astro Thermal Fire PS Fire Sleeves penetrating 150mm minimum thickness rigid floors for up to EI120 applications

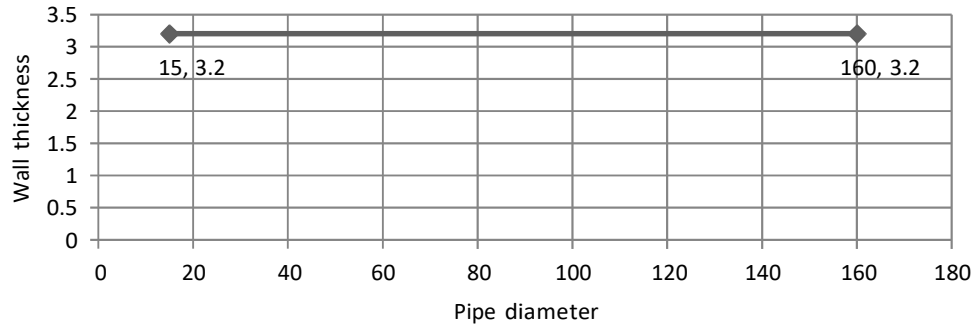

B.7 Field of application for Astro Thermal Fire PS Fire Sleeve – Circular for PVC-U (according to EN 1329-1)* and HDPE (according to EN 1519-1)* pipes penetrating fire resistant floors for applications up to EI120:

The pipe may be fitted within rigid floors constructed in accordance with section 1.2.1 of this ETA with a minimum 150mm thickness.

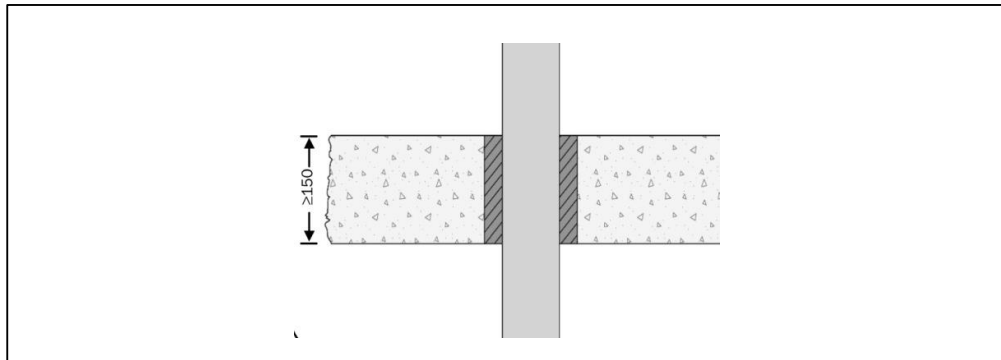

- The seal must be a minimum of 150mm long fitted flush with the underside of the floor slab
- The seal must be friction fitted within an aperture nominally 50mm larger than the outside diameter of the pipe
- A support must be provided above the floor a maximum of 450mm from the surface of the floor
- Pipe end configurations U/C, C/C are covered for use
- Intumescent acrylic mastic may be used in addition to seal between the Astro Thermal Fire PS Fire Sleeve and the floor slab if required
- Pipe penetration seals must be fitted a minimum of 200mm apart.

* In Germany, the PVC-U pipes have to comply additionally to DIN 8062 & HDPE pipes additionally to DIN 8074.

B.7.1 The Line graph below shows the coverage of t h e allowable PVC-U (according to EN 1329-1)* pipe diameters and wall thickness for applications up to EI120: (any pipe size variation along the line is covered)

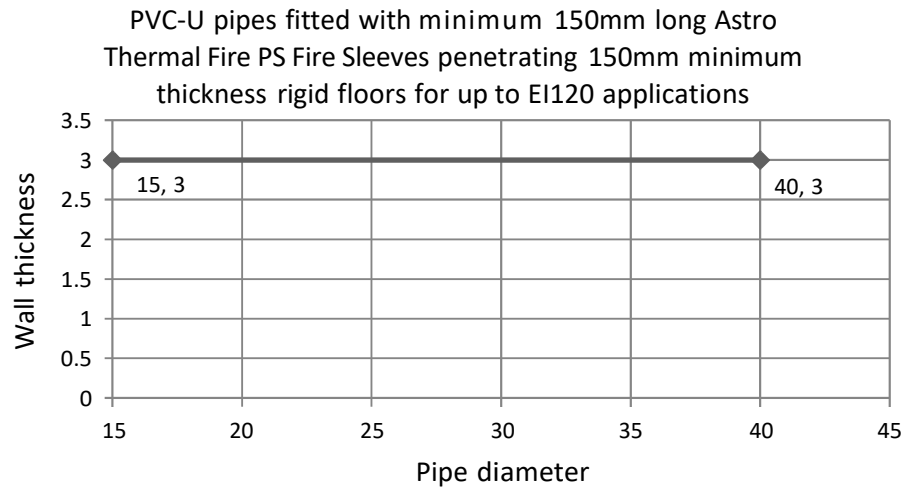

B.7.2 The line graph below shows the coverage of the allowable HDPE (according to EN 1519-1)* pipe diameters and wall thickness for applications up to EI120: (any pipe size variation along the lines and the area between the lines is covered)

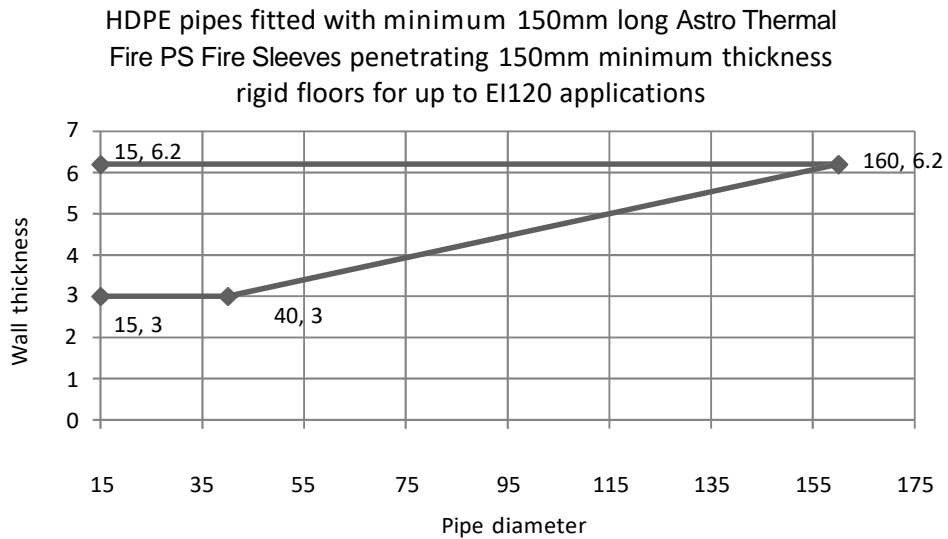

* In Germany, the PVC-U pipes have to comply additionally to DIN 8062 & HDPE pipes additionally to DIN 8074.

B.8 Field of application for Astro Thermal Fire PS Fire Sleeve in conjunction with fire stopping compound – Circular for PVC-U (according to EN 1329-1)* and HDPE (according to EN 1519-1)* pipes penetrating fire resistant floors for applications up to EI120:

The pipe may be fitted within rigid floors constructed in accordance with section 1.2.1 of this ETA with a minimum 150mm thickness.

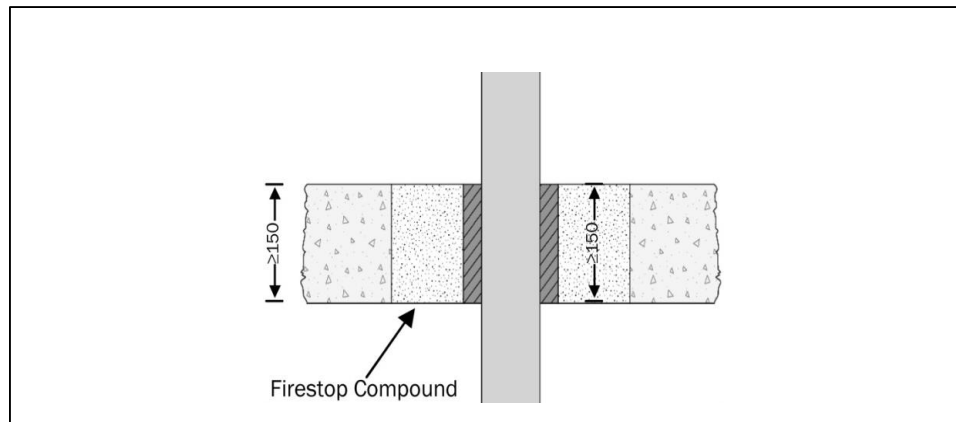

- The seal must be a minimum of 150mm long fitted flush with the underside of the floor slab
- The seal may be fitted within an aperture of up to 330mm x 330mm
- The remaining aperture must be filled with Astroflame Ltd Astro FL compound. This product is both a non-combustible and dimensionally stable gypsum mortar which would be classified A1
- The seal must be cast within the fire stopping compound
- A minimum of 60mm of compound must be present between the outside of the seal and the edge of aperture
- A support must be provided above the floor a maximum of 450mm from the surface of the floor
- Pipe end configurations U/C, C/C are covered for use
- Pipe penetration seals must be fitted a minimum of 200mm apart.

* In Germany, the PVC-U pipes have to comply additionally to DIN 8062 & HDPE pipes additionally to DIN 8074.

B.8.1 The line graph below shows the coverage of the allowable PVC-U (according to EN 1329-1)* pipe diameters and wall thickness for applications up to EI90: (any pipe size variation along the line is covered)

PVC-U pipes fitted with minimum 150mm long Astro Thermal Fire PS Fire Sleeve cast within fire stopping compound penetrating 150mm minimum thickness rigid floors for up to EI90 applications

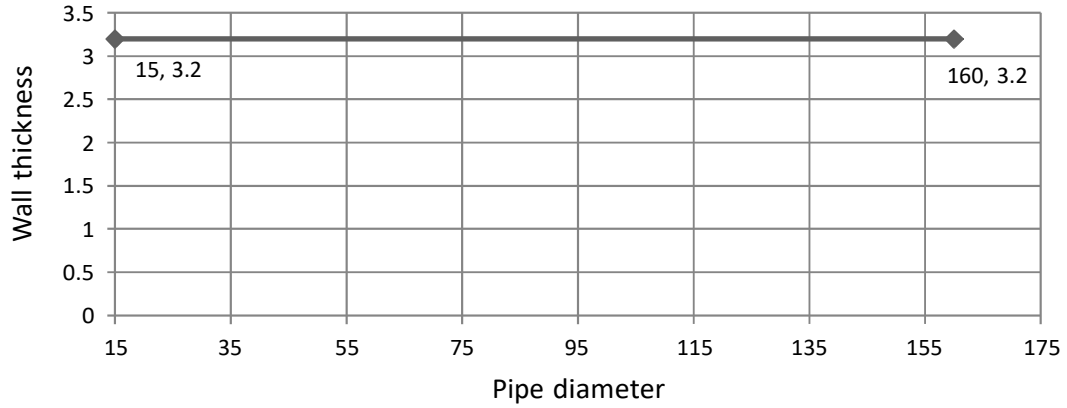

* In Germany, the PVC-U pipes have to comply additionally to DIN 8062 & HDPE pipes additionally to DIN 8074.

B.8.2 The line graph below shows the coverage of the allowable PVC-U (according to EN 1329-1)* pipe diameters and wall thickness for applications up to EI120: (any pipe size variation along the line is covered)

PVC-U pipes fitted with minimum 150mm long Astro Thermal Fire PS Fire Sleeve cast within fire stopping compound penetrating 150mm minimum thickness rigid floors for up to EI120 applications

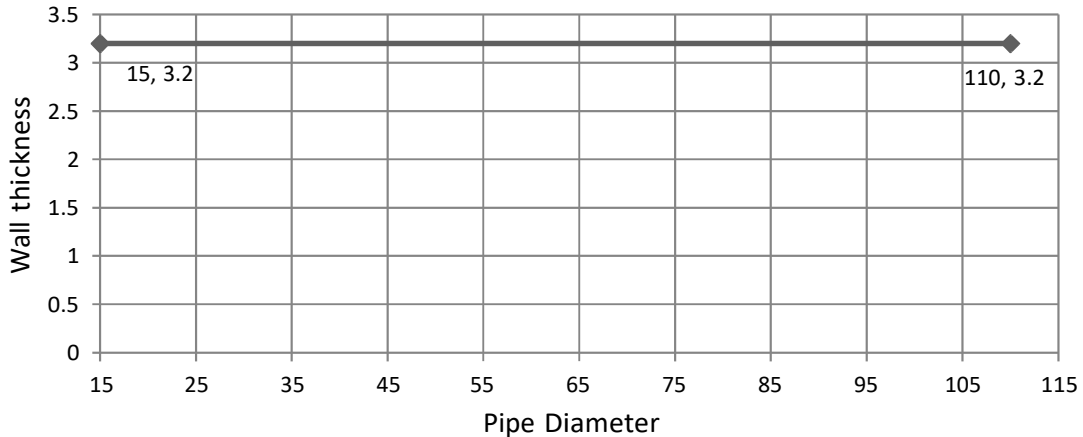

B.8.3 The line graph below shows the coverage of the allowable HDPE (according to EN 1519-1)* pipe diameters and wall thickness for applications up to EI120: (any pipe size variation along the line is covered)

HDPE pipes fitted with minimum 150mm long Astro Thermal Fire PS Fire Sleeve cast within fire stopping compound penetrating 150mm minimum thickness rigid floors for up to EI120 applications

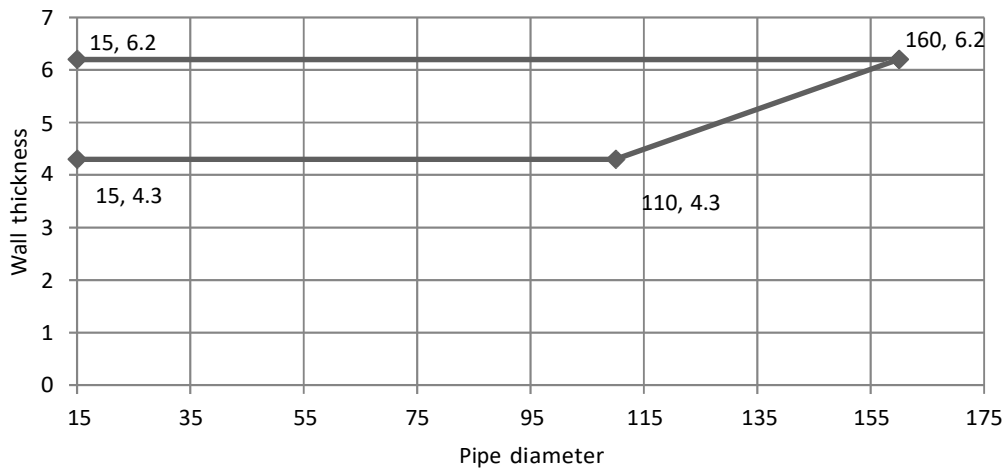

* In Germany, the PVC-U pipes have to comply additionally to DIN 8062 & HDPE pipes additionally to DIN 8074.

ANNEX C: RESISTANCE TO FIRE CLASSIFICATION CONTINUED

Contents

Section

- C Astro Thermal Fire PS+ Fire Sleeve and Astro DS Duct Sleeve+ coverage**
- C.1 Field of application for minimum 180mm long Astro Thermal Fire PS+ Fire Sleeve – Circular for PVC-U (according to EN 1329-1)* and HDPE (according to EN 1519-1)* pipes penetrating fire resistant walls for applications up to EI120**
- C.1.2 Graph showing the coverage of the allowable PVC-U (according to EN 1329-1) pipe diameters and wall thickness for applications up to EI120
- C.1.3 Graph showing the coverage of the allowable HDPE (according to EN1519-1) pipe diameters and wall thickness for applications up to EI120
- C.2 Field of application for minimum 150mm long Astro DS Duct Sleeve+ – Circular for PVC-U circular ambient pressure extraction and ventilation ‘duct’ type pipes penetrating fire resistant walls for applications up to EI120**
- C.2.1 Graph showing the coverage of the allowable PVC-U circular ambient pressure extraction and ventilation ‘duct’ type pipe diameters and wall thickness for applications up to EI120
- C.3 Field of application for minimum 280mm long Astro DS Duct Sleeve+ – Circular for PVC-U circular ambient pressure extraction and ventilation ‘duct’ type pipes penetrating fire resistant walls for applications up to EI120**
- C.3.1 Graph showing the coverage of the allowable PVC-U circular ambient pressure extraction and ventilation ‘duct’ type pipe diameters and wall thickness for applications up to EI120
- C.4 Field of application for minimum 150mm long Astro Thermal Fire PS+ Fire Sleeve – Circular for PVC-U (according to EN 1329-1)* pipes penetrating fire resistant masonry walls only for applications up to EI240**
- C.4.1 Graph showing the coverage of the allowable PVC-U (according to EN 1329-1) pipe diameters and wall thickness for applications up to EI240
- C.5 Field of application for Astro DS Duct Sleeve+ – Rectangular for use with a 200mm wide x 60mm high PVC-U ambient pressure extraction and ventilation ‘duct’ type pipe penetrating fire resistant masonry walls for applications up to EI240**
- C.6 Field of application for Astro Thermal Fire PS+ Fire Sleeve – Circular for PVC-U (according to EN 1329-1)* and HDPE EN 1519-1)* pipes penetrating fire resistant floors for applications up to EI120**
- C.6.1 Graph showing the coverage of the allowable PVC-U (according to EN 1329-1) pipe diameters and wall thickness for applications up to EI120
- C.6.2 Graph showing the coverage of the allowable HDPE (according to EN 1519-1) pipe diameters and wall thickness for applications up to EI120

* In Germany, the PVC-U pipes have to comply additionally to DIN 8062 & HDPE pipes additionally to DIN 8074.

- C.7 Field of application for Astro Thermal Fire PS+ Fire Sleeve in conjunction with fire stopping compound – Circular for PVC-U (according to EN 1329-1)* and HDPE (according to EN 1519-1)* pipes penetrating fire resistant floors for applications up to EI120**
- C.7.1 Graph showing the coverage of the allowable PVC-U (according to EN 1329-1) pipe diameters and wall thickness for applications up to EI12
- C.7.2 Graph showing the coverage of the allowable HDPE (according to EN 1519-1) pipe diameters and wall thickness for applications up to EI120

** In Germany, the PVC-U pipes have to comply additionally to DIN 8062 & HDPE pipes additionally to DIN 8074.*

C Astro Thermal Fire PS+ Fire Sleeve and Astro DS Duct Sleeve+ coverage

- C.1 Field of application for minimum 180mm long Astro Thermal Fire PS+ Fire Sleeve – Circular for PVC-U (according to EN 1329-1)* and HDPE (according to EN 1519-1)* pipes penetrating fire resistant walls for applications up to EI120:**

The pipe may be fitted within both flexible and rigid walls constructed in accordance with section 1.2.1 of this ETA with a minimum 132mm thickness. For flexible walls using steel stud the wall can be constructed with or without cavity insulation

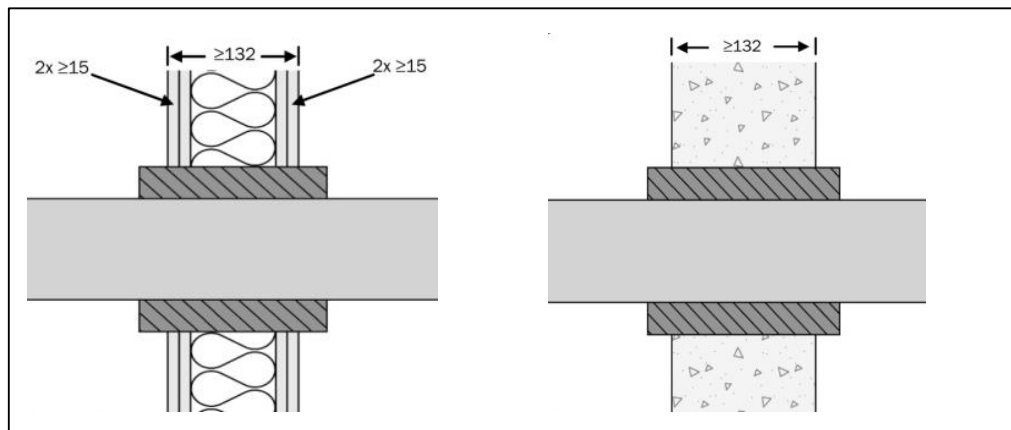

** In Germany, the PVC-U pipes have to comply additionally to DIN 8062 & HDPE pipes additionally to DIN 8074.*

The seal must be a minimum of 180mm long with 24mm protruding each side of the wall

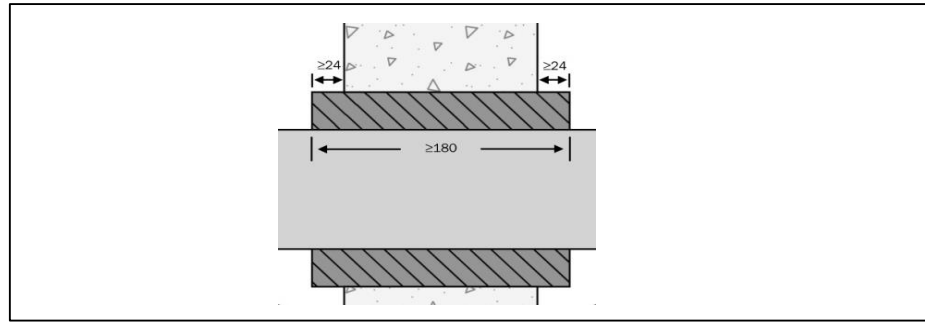

- If the wall is thicker than 132mm the seal must be longer to maintain the 24mm protruding from each face
- The seal must be friction fitted within an aperture nominally 58mm larger than the outside diameter of the pipe
- A support must be provided each side of the wall a maximum of 150mm from the surface of the wall
- All pipe end configurations U/U, C/U, U/C, C/C are covered for use
- Intumescent acrylic mastic may be used in addition to seal between the Astro Thermal Fire PS+ Fire Sleeve and the wall if required
- Pipe penetration seals must be fitted a minimum of 200mm apart.

C.1.2 The line graph below shows the coverage of the allowable PVC-U (according to EN 1329-1)* pipe diameters and wall thickness for applications up to EI120: (any pipe size variation along the line is covered)

PVC-U pipes fitted with minimum 180mm long Astro Thermal Fire PS+ Fire Sleeves penetrating 132mm minimum thickness flexible or rigid walls for up to EI120 applications

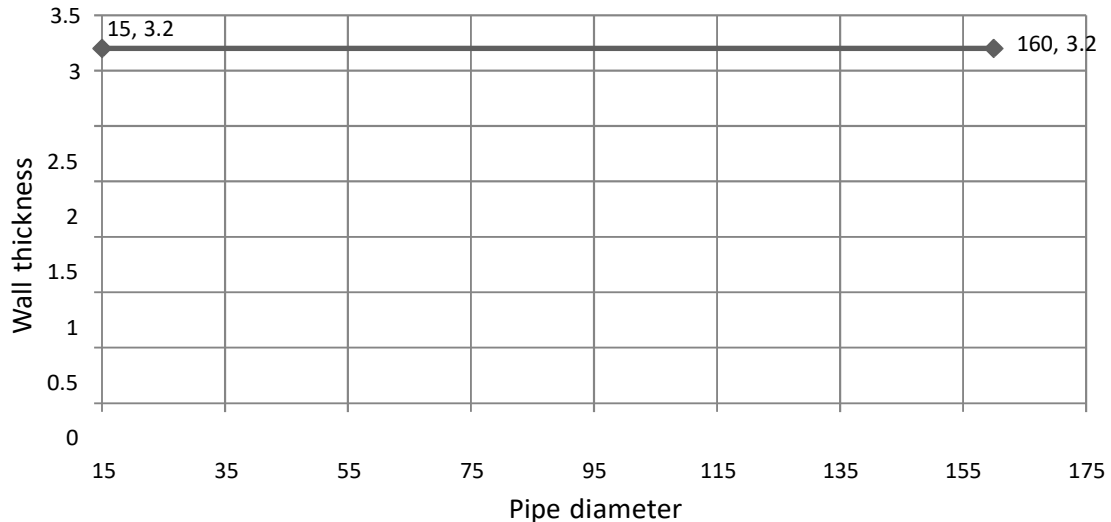

* In Germany, the PVC-U pipes have to comply additionally to DIN 8062 & HDPE pipes additionally to DIN 8074.

C.1.3 The line graphs below show the coverage of the allowable HDPE (according to EN 1519-1)* pipe diameters and wall thickness for applications up to EI120: (any pipe size variation along the line is covered)

HDPE pipes fitted with minimum 180mm long Astro Thermal Fire PS+ Fire Sleeves penetrating 132mm minimum thickness flexible or rigid walls for up to EI120 applications

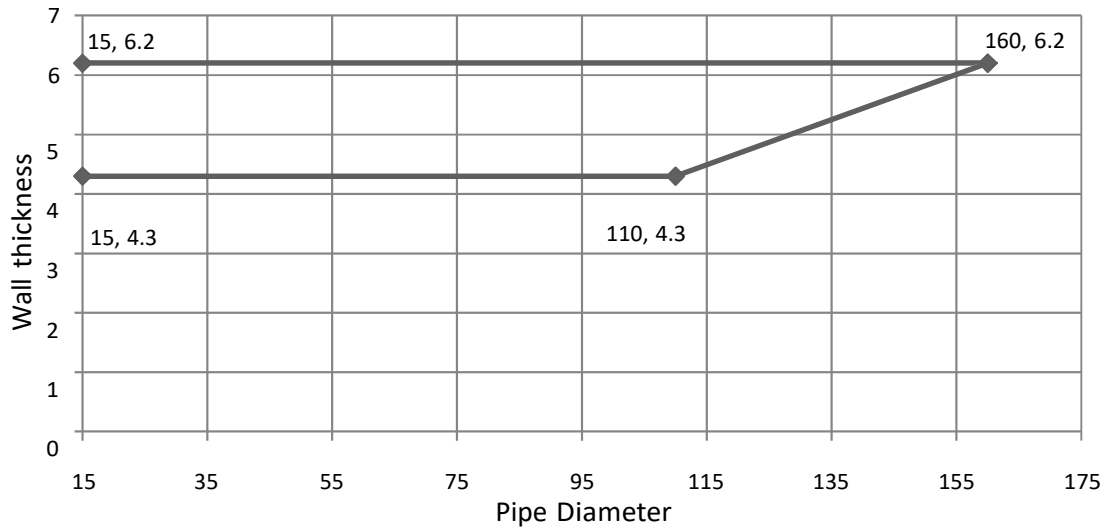

* In Germany, the PVC-U pipes have to comply additionally to DIN 8062 & HDPE pipes additionally to DIN 8074.

C.2 Field of application for minimum 150mm long Astro DS Duct Sleeve+ – Circular for PVC-U circular ambient pressure extraction and ventilation ‘duct’ type pipes penetrating fire resistant walls for applications up to EI120:

The pipe may be fitted within both flexible and rigid walls constructed in accordance with section 1.2.1 of this ETA with a minimum 132mm thickness. For flexible walls using steel stud the wall can be constructed with or without cavity insulation

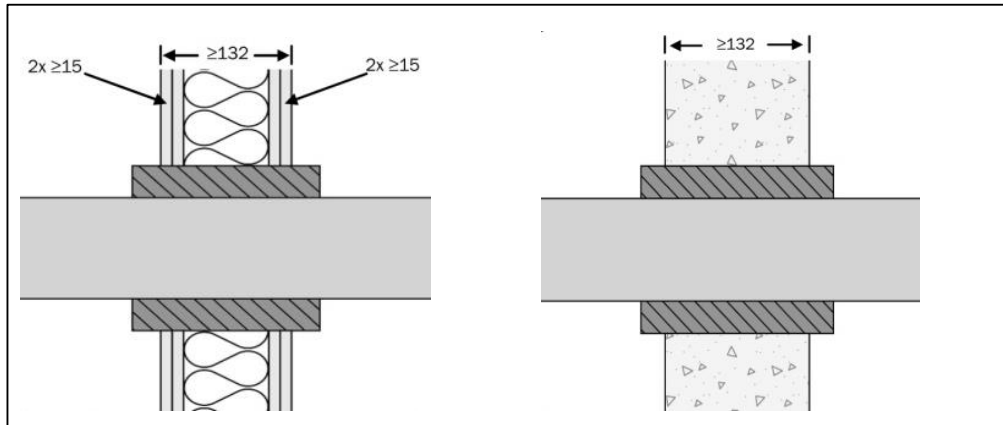

The seal must be a minimum of 150mm long with 9mm protruding each side of the wall

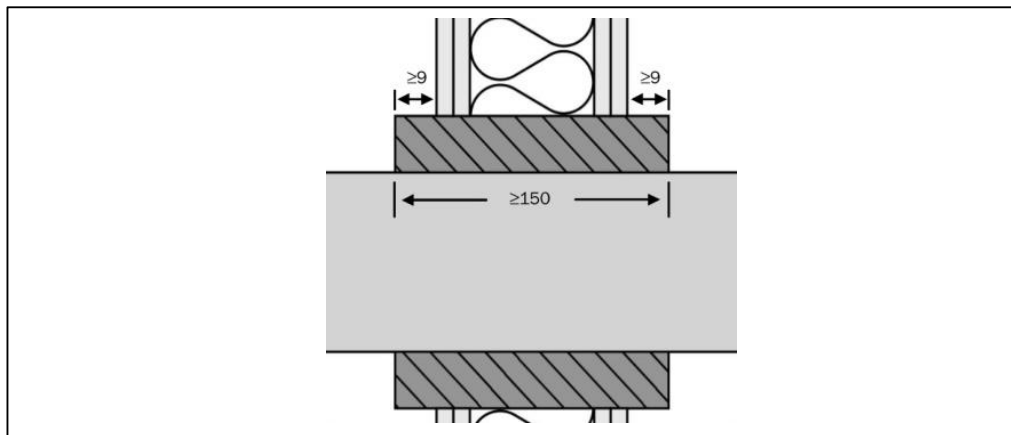

- If the wall is thicker than 132mm the seal must be longer to maintain the 9mm protruding from each face
- The seal must be friction fitted within an aperture nominally 58mm larger than the outside diameter of the pipe
- For flexible walls constructed with steel studs then the wall can be fitted with or without cavity insulation
- A support must be provided each side of the wall a maximum of 150mm from the surface of the wall
- All pipe end configurations U/U, C/U, U/C, C/C are covered for use
- Intumescent acrylic mastic may be used in addition to seal between the Astro DS Duct Sleeve+ and the wall if required
- Pipe penetration seals must be fitted a minimum of 200mm apart.

C.2.1 The line graph below shows the coverage of the allowable PVC-U circular ambient pressure extraction and ventilation 'duct' type pipe diameters and wall thickness for applications up to EI120: (any pipe size variation along the line is covered)

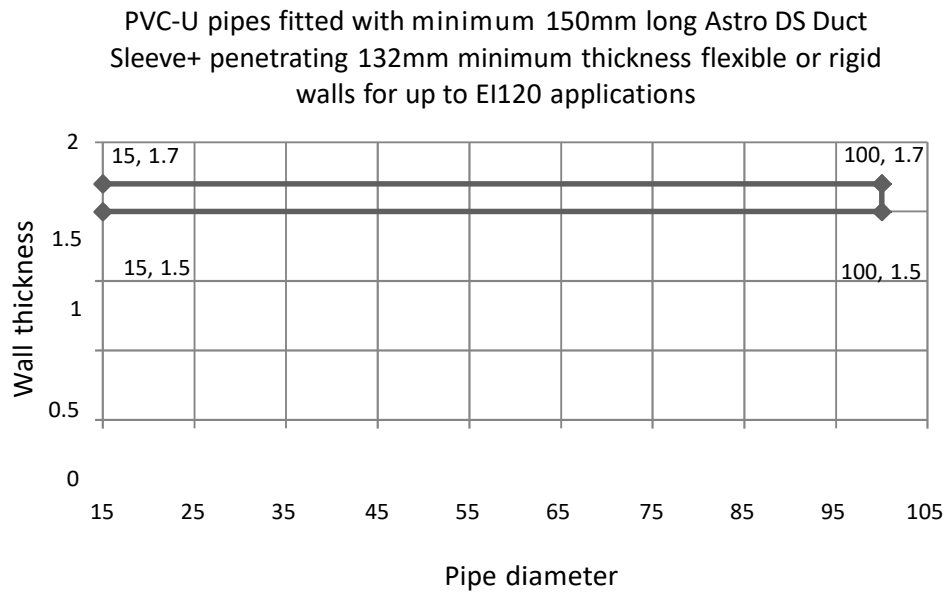

C.3 Field of application for minimum 280mm long Astro DS Duct Sleeve+ – Circular for PVC-U circular ambient pressure extraction and ventilation 'duct' type pipes penetrating fire resistant walls for applications up to EI120:

The pipe may be fitted within both flexible and rigid walls constructed in accordance with section 1.2.1 of this ETA with a minimum 132mm thickness. For flexible walls using steel stud the wall can be constructed with or without cavity insulation

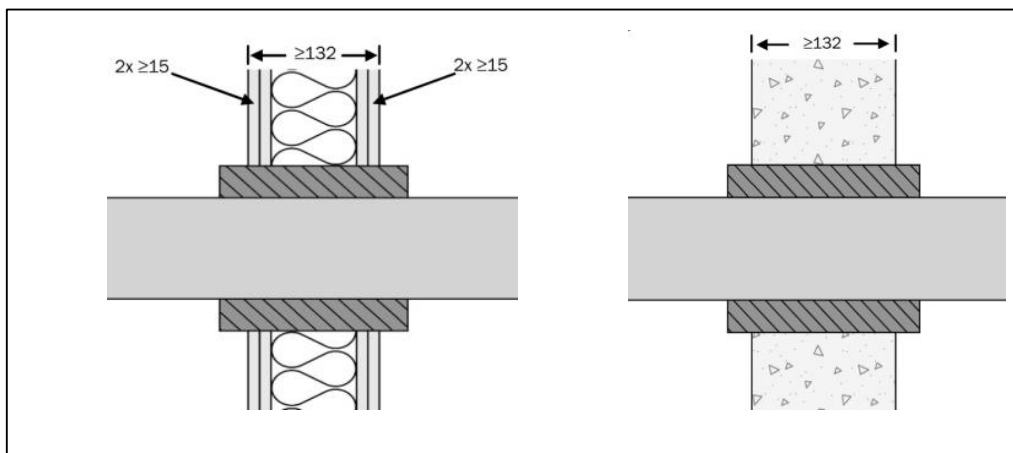

The seal must be a minimum of 280mm long with 74mm protruding each side

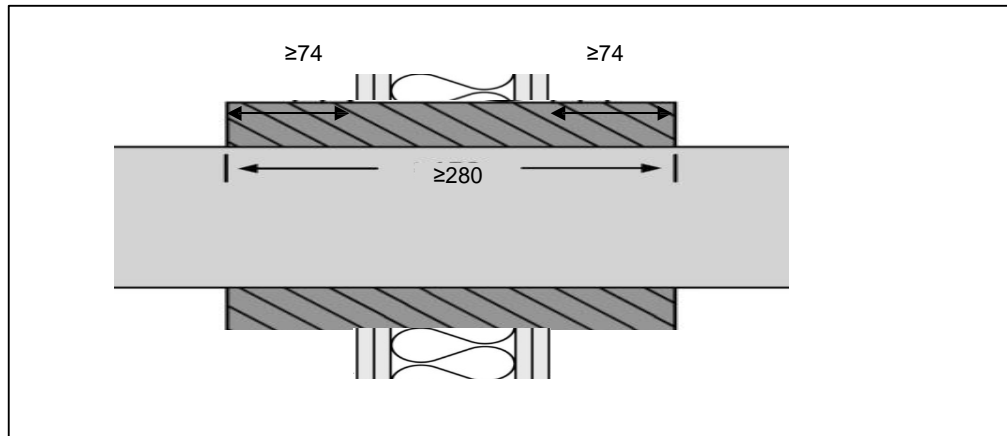

- If the wall is thicker than 132mm the seal must be longer to maintain the 74mm protruding from each face
- The seal must be friction fitted within an aperture nominally 58mm larger than the outside diameter of the pipe
- For flexible walls constructed with steel studs then the wall can be fitted with or without cavity insulation
- A support must be provided each side of the wall a maximum of 150mm from the surface of the wall
- All pipe end configurations U/U, C/U, U/C, C/C are covered for use
- Intumescent acrylic mastic may be used in addition to seal between the Astro DS Duct Sleeve+ and the wall if required
- Pipe penetration seals must be fitted a minimum of 200mm apart.

C.3.1 The line graph below shows the coverage of the allowable PVC-U circular ambient pressure extraction and ventilation 'duct' type pipe diameters and wall thickness for applications up to E1120: (any pipe size variation along the line is covered)

PVC-U pipes fitted with minimum 280mm long Astro DS Duct Sleeve+ penetrating 132mm minimum thickness flexible or rigid walls for up to E1120 applications

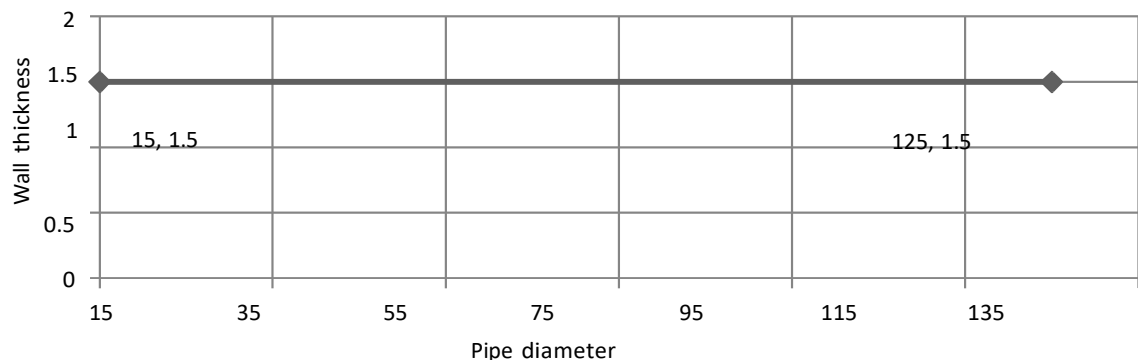

C.4 Field of application for minimum 150mm long Astro Thermal Fire PS+ Fire Sleeve – Circular for PVC-U (according to EN 1329-1)* pipes penetrating fire resistant masonry walls only for applications up to EI240

An Astro Thermal Fire PS+ Fire Sleeve may be used on pipes up to 110mm diameter x 3.2mm thick PVC-U pipe provided the following criteria are met:

- The pipe may only be fitted within a rigid wall constructed in accordance with section 1.2.1 of this ETA with a minimum 150mm thickness.
- The seal must be a minimum of 150mm long finishing flush with each side of the wall
- The seal must be friction fitted within an aperture nominally 58mm large than the external pipe diameter
- A support must be provided each side of the wall a maximum of 150mm from the surface of the wall
- Only 3.2mm wall thickness pipe is used
- Pipe penetration seals must be fitted a minimum of 200mm apart
- All pipe end configurations U/U, C/U, U/C, C/C are covered for use.

C.4.1 The line graph below shows the coverage of the allowable PVC (according to EN 1329-1)* pipe diameters and wall thickness for applications up to EI240: (any pipe size variation along the line is covered)

PVC-U pipes fitted with minimum 150mm long Astro Thermal Fire PS+ Fire Sleeves penetrating 150mm minimum thickness rigid walls for up to EI240 applications

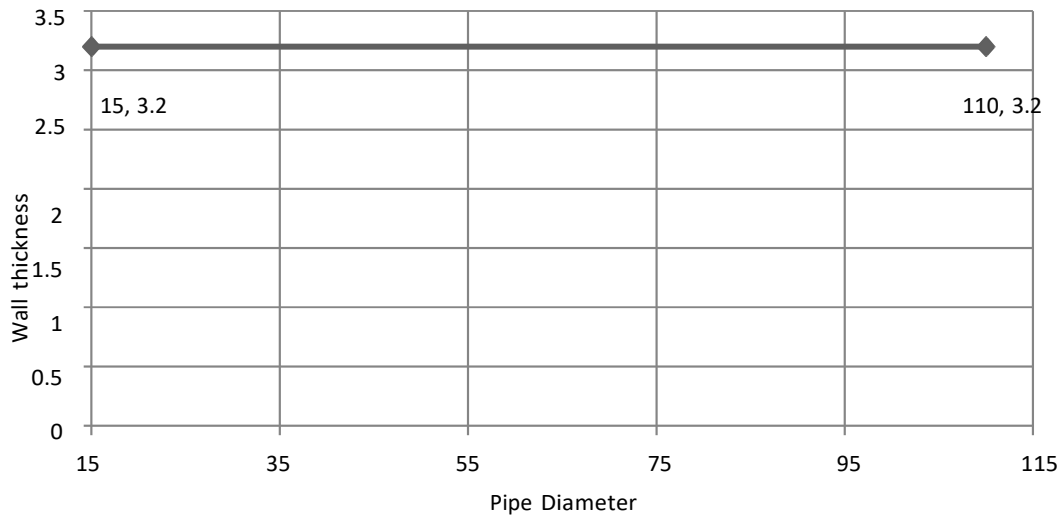

* In Germany, the PVC-U pipes have to comply additionally to DIN 8062 & HDPE pipes additionally to DIN 8074.

C.5 Field of application for Astro DS Duct Sleeve+ – Rectangular for use with a 200mm wide x 60mm high PVC-U rectangular ambient pressure extraction and ventilation ‘duct’ type pipe penetrating fire resistant masonry walls for applications up to EI240:

An Astro DS Duct Sleeve+ may be used on a 200mm wide x 60mm high x 1.5-1.7mm wall thickness PVC-U rectangular pipe (duct) provided the following criteria are met:

- The pipe may only be fitted within a rigid walls constructed in accordance with section 1.2.1 of this ETA with a minimum 150mm thickness.
- The seal must be a minimum of 180mm long with 15mm protruding each side of the wall
- The seal must be friction fitted within an aperture nominally 58mm larger the external pipe size.
- A support must be provided each side of the wall a maximum of 150mm from the surface of the wall
- Intumescent acrylic mastic may be used in addition to seal between the Astro DS Duct Sleeve+ and the wall if required
- Pipe penetration seals must be fitted a minimum of 200mm apart
- Pipe end configurations U/U, C/U, U/C, C/C are covered for use.

C.6 Field of application for Astro Thermal Fire PS+ Fire Sleeve – Circular for PVC-U (according to EN 1329-1)* and HDPE (according to EN 1519-1)* pipes penetrating fire resistant floors for applications up to EI120:

The pipe may be fitted within rigid floors constructed in accordance with section 1.2.1 of this ETA with a minimum 150mm thickness.

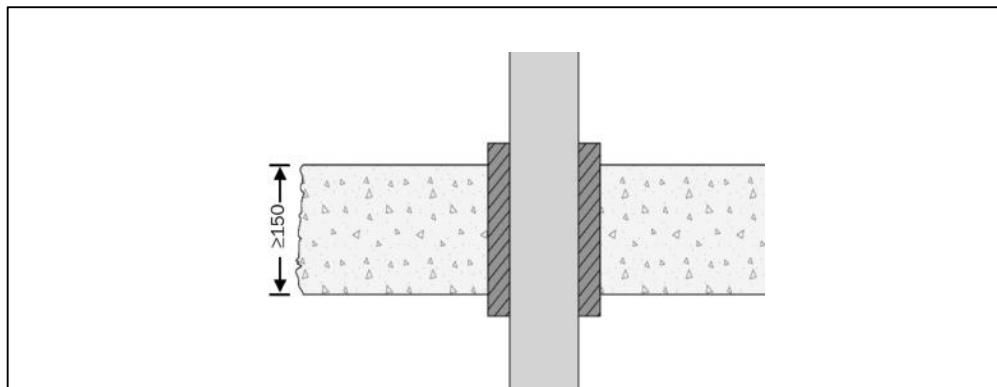

- The seal must be a minimum of 200mm long with 25mm protruding above and below the floor slab
- The seal must be friction fitted within an aperture nominally 58mm larger than the outside diameter of the pipe
- A support must be provided above the floor a maximum of 450mm from the surface of the floor
- Pipe end configurations U/U, C/U, U/C, C/C are covered for use
- Intumescent acrylic mastic may be used in addition to seal between the Astro Thermal Fire PS+ Fire Sleeve and the floor slab if required
- Pipe penetration seals must be fitted a minimum of 200mm apart.

* In Germany, the PVC-U pipes have to comply additionally to DIN 8062 & HDPE pipes additionally to DIN 8074.

C.6.1 The line graph below shows the coverage of the allowable PVC (according to EN 1329-1)* pipe diameters and wall thickness for applications up to EI120: (any pipe size variation along the line is covered)

PVC-U pipes fitted with minimum 200mm long Astro Thermal Fire PS+ Fire Sleeve penetrating 150mm minimum thickness rigid floors for up to EI120 applications

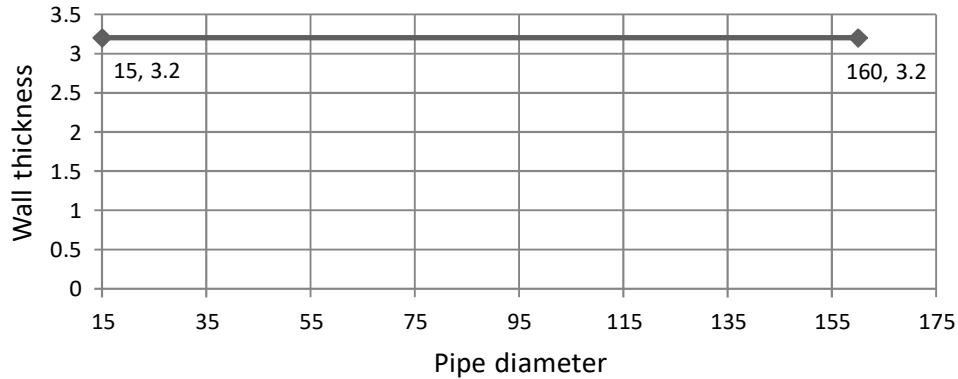

C.6.2 The line graph below shows the coverage of the allowable HDPE (according to EN 1519-1)* pipe diameters and wall thickness for applications up to EI120: (any pipe size variation along the line is covered)

HDPE pipes fitted with minimum 200mm long Astro Thermal Fire PS+ Fire Sleeve penetrating 150mm minimum thickness rigid floors for up to EI120 applications

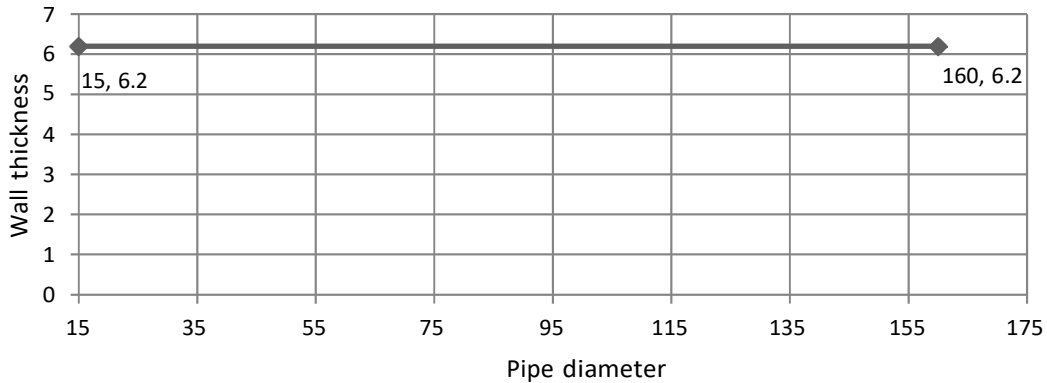

* In Germany, the PVC-U pipes have to comply additionally to DIN 8062 & HDPE pipes additionally to DIN 8074.

C.7 Field of application for Astro Thermal Fire PS+ Fire Sleeve in conjunction with fire stopping compound – Circular for PVC-U (according to EN 1329-1)* and HDPE (according to EN 1519-1* pipes penetrating fire resistant floors for applications up to EI120:

The pipe may be fitted within rigid floors constructed in accordance with section 1.2.1 of this ETA with a minimum 150mm thickness.

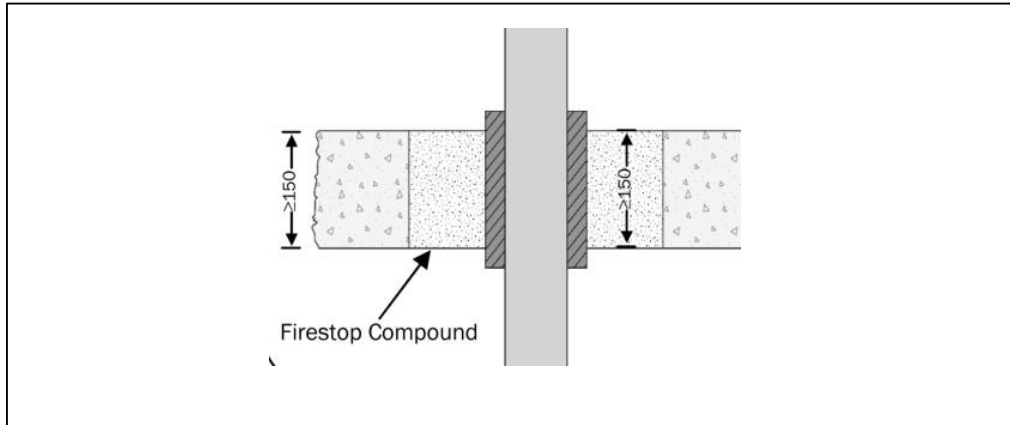

- The seal must be a minimum of 200mm long with 25mm protruding above and below the floor slab
- The seal may be fitted within an aperture of up to 330mm x 330mm
- The remaining aperture must be filled with Astroflame Ltd Astro FL compound. This product is both non-combustible and a dimensionally stable gypsum mortar which would be classified A1
- The seal must be cast within the fire stopping compound
- A minimum of 60mm of compound must be present between the outside of the seal and the edge of aperture
- A support must be provided above the floor a maximum of 450mm from the surface of the floor
- Pipe end configurations U/U, C/U, U/C, C/C are covered for use
- Pipe penetration seals must be fitted a minimum of 200mm apart.

* In Germany, the PVC-U pipes have to comply additionally to DIN 8062 & HDPE pipes additionally to DIN 8074.

C.7.1 The line graph below shows the coverage of the allowable PVC-U (according to EN 1329-1)* pipe diameters and wall thickness for applications up to EI120: (any pipe size variation along the line is covered)

PVC-U pipes fitted with minimum 200mm long Astro Thermal Fire PS+ Fire Sleeve cast within fire stopping compound penetrating 150mm minimum thickness rigid floors for up to EI120 applications

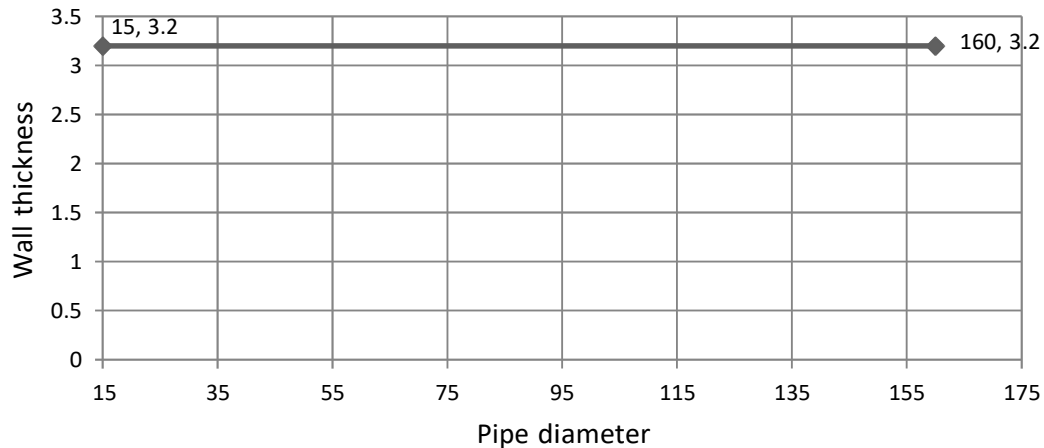

C.7.2 The line graph below shows the coverage of the allowable HDPE (according to EN 1519-1)* pipe diameters and wall thickness for applications up to EI120: (any pipe size variation along and between the lines is covered)

HDPE pipes fitted with minimum 200mm long Astro Thermal Fire PS+ Fire Sleeve cast within fire stopping compound penetrating 150mm minimum thickness rigid floors for up to EI120 applications

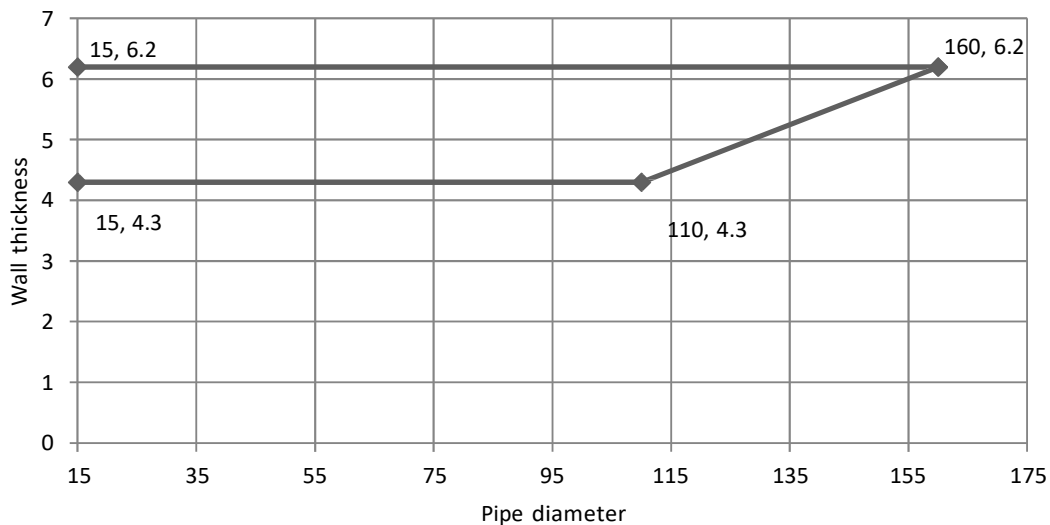

* In Germany, the PVC-U pipes have to comply additionally to DIN 8062 & HDPE pipes additionally to DIN 8074.

ANNEX D: RESISTANCE TO FIRE CLASSIFICATION CONTINUED

Contents

Section

- D Astro DS+ Low Profile (LP) Duct Sleeve coverage**
- D.1 Field of application for minimum 150mm long Astro DS+ Low Profile (LP) Duct Sleeve – Circular (Standard Sleeve) for PVC-U circular ambient pressure extraction and ventilation ‘duct’ type pipes penetrating fire resistant walls for applications up to EI120 in walls of minimum 100mm thick**
- D.1.1 Graph showing the coverage of the allowable PVC-U circular ambient pressure extraction and ventilation duct’ type pipe diameters and all thickness for applications up to EI120 in minimum 100mm thick walls
- D.2 Field of application for minimum 250mm long Astro DS+ Low Profile (LP) Duct Sleeve – Circular (Standard Sleeve) for PVC-U circular ambient pressure extraction and ventilation ‘duct’ type pipes penetrating fire resistant walls for applications up to EI120 in walls of minimum 100mm thick**
- D.2.1 Graph showing the coverage of the allowable PVC-U circular ambient pressure extraction and ventilation duct’ type pipe diameters and all thickness for applications up to EI120 in minimum 100mm thick walls
- D.3 Field of application for minimum 250mm long Astro DS+ Low Profile (LP) Duct Sleeve – Circular (Enhanced Sleeve) for PVC-U circular ambient pressure extraction and ventilation ‘duct’ type pipes penetrating fire resistant walls for applications up to EI120**
- D.3.1 Graph showing the coverage of the allowable PVC-U circular ambient pressure extraction and ventilation ‘duct’ type pipe diameters and wall thickness for applications up to EI120
- D.4 Field of application for Astro DS+ Low Profile (LP) Duct Sleeve – Rectangular (Standard Sleeve) for use with a 204mm wide x 60mm high PVC-U rectangular ambient pressure extraction and ventilation ‘duct’ type pipe penetrating fire resistant walls for applications up to EI120**
- D.5 Field of application for Astro DS+ Low Profile (LP) Duct Sleeve – Rectangular (Standard Sleeve) for use with a 110mm wide x 54mm high PVC-U rectangular ambient pressure extraction and ventilation ‘duct’ type pipe penetrating fire resistant walls for applications up to EI120**
- D.6 Field of application for Astro DS+ Low Profile (LP) Duct Sleeve – Rectangular (Enhanced Sleeve) for use with a 220mm wide x 90mm high PVC-U rectangular ambient pressure extraction and ventilation ‘duct’ type pipe penetrating fire resistant walls for applications up to EI120**

** In Germany, the PVC-U pipes have to comply additionally to DIN 8062 & HDPE pipes additionally to DIN 8074.*

D Astro DS+ Low Profile (LP) Duct Sleeve Coverage

D.1 Field of application for minimum 150mm long Astro DS+ Low Profile (LP) Duct Sleeve – Circular (Standard Sleeve) for PVC-U circular ambient pressure extraction and ventilation 'duct' type pipes penetrating minimum 100mm thick fire resistant walls for applications up to EI120:

The pipe may be fitted within both flexible and rigid walls constructed in accordance with section 1.2.1 of this ETA with a minimum 100mm thickness. For flexible walls using steel stud the wall can be constructed with or without cavity insulation.

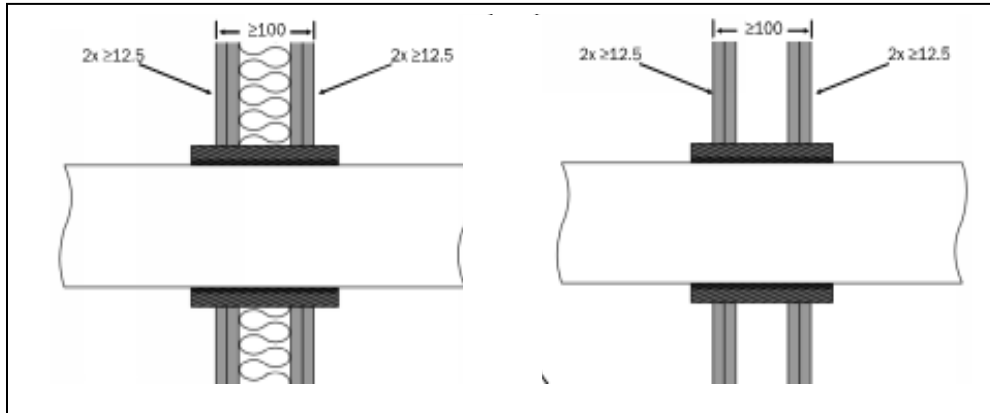

The seal must be a minimum of 150mm long with 25mm protruding each side

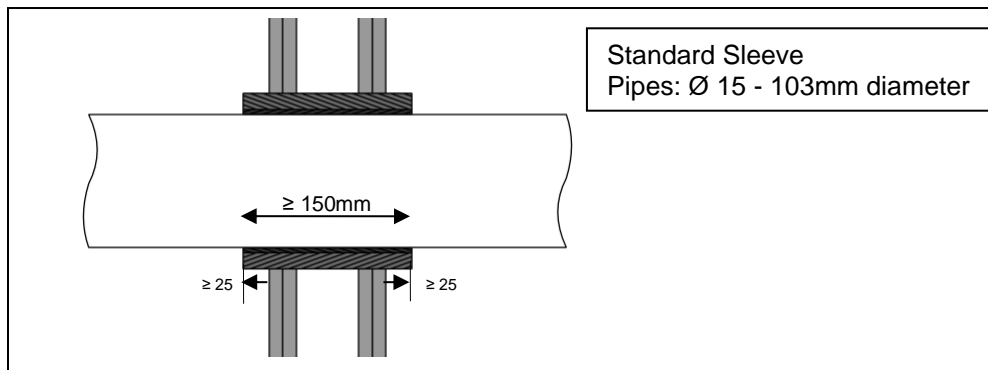

- If the wall is thicker than 100mm the seal must be longer to maintain the 25mm protruding from each face
- The seal must be friction fitted within an aperture nominally 30mm larger than the outside diameter of the pipe
- A support must be provided each side of the wall a maximum of 300mm from the surface of the wall
- All pipe end configurations U/U, C/U, U/C, C/C are covered for use
- Intumescent acrylic mastic may be used in addition to seal between the Astro DS+ Low Profile (LP) Duct Sleeve and the wall if required
- Pipe penetration seals must be fitted a minimum of 200mm apart.

D.1.1 The line graph below shows the coverage of the allowable PVC-U circular ambient pressure extraction and ventilation 'duct' type pipe diameters and wall thickness for applications up to EI120 in minimum 100mm thick walls: (any pipe size variation along the line is covered)

PVC-U pipes fitted with minimum 150mm long Astro DS+ Low Profile (LP) Duct Sleeve
 - Circular (Standard Sleeve) Fire Sleeves penetrating 100mm minimum thickness flexible or rigid walls for up to EI120 applications

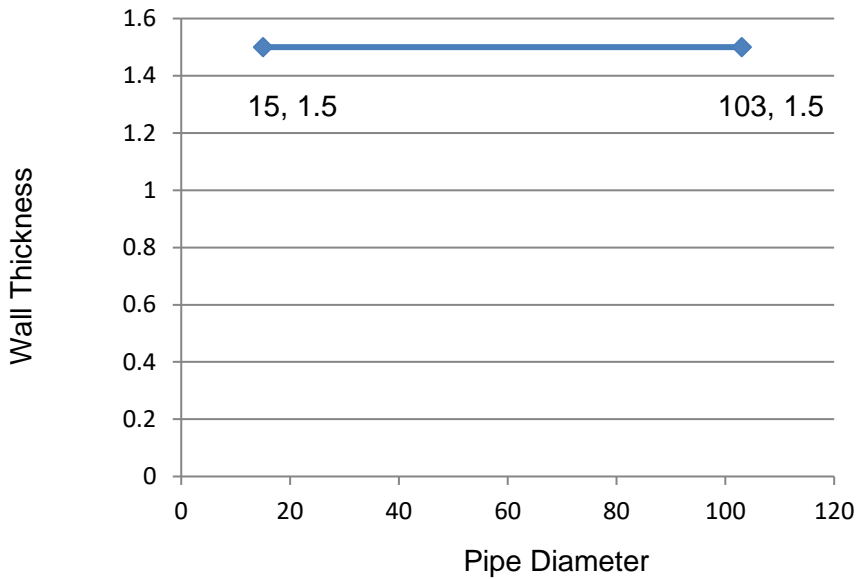

D.2 Field of application for minimum 250mm long Astro DS+ Low Profile (LP) Duct Sleeve – Circular (Standard Sleeve) for PVC-U circular ambient pressure extraction and ventilation 'duct' type pipes penetrating minimum 100mm thick fire resistant walls for applications up to EI120:

The pipe may be fitted within both flexible and rigid walls constructed in accordance with section 1.2.1 of this ETA with a minimum 100mm thickness. For flexible walls using steel stud the wall can be constructed with or without cavity insulation.

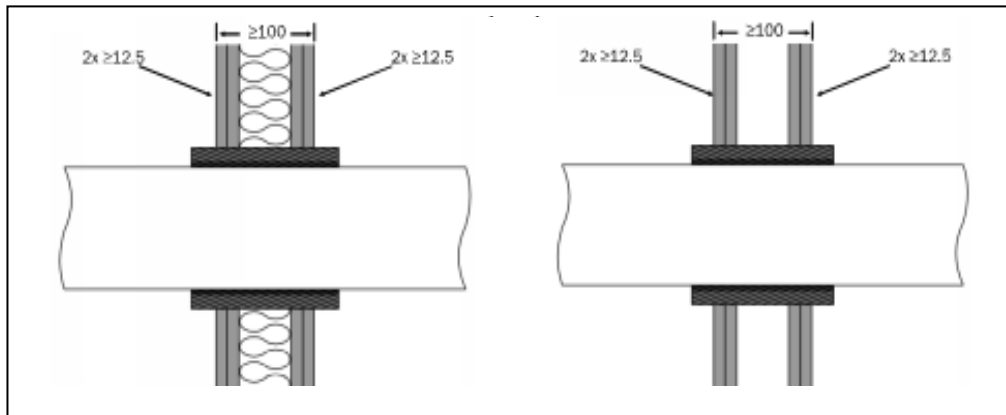

The seal must be a minimum of 250mm long with 75mm protruding each side

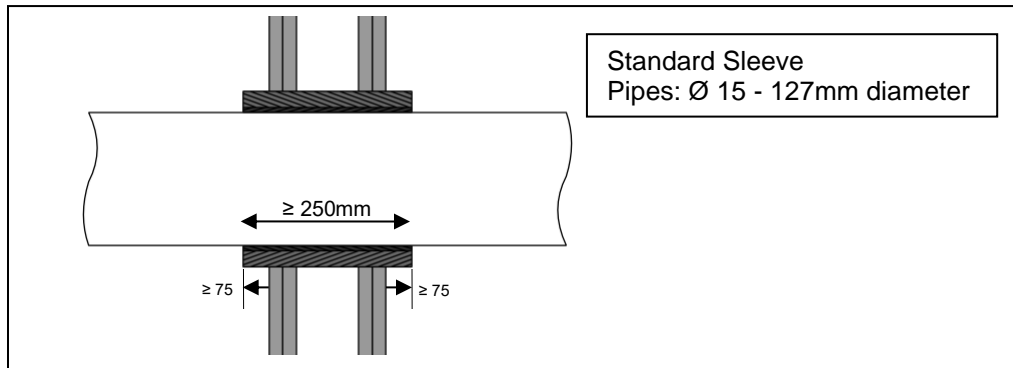

- If the wall is thicker than 100mm the seal must be longer to maintain the 75mm protruding from each face
- The seal must be friction fitted within an aperture nominally 30mm larger than the outside diameter of the pipe
- A support must be provided each side of the wall a maximum of 300mm from the surface of the wall
- All pipe end configurations U/U, C/U, U/C, C/C are covered for use
- Intumescent acrylic mastic may be used in addition to seal between the Astro DS+ Low Profile (LP) Duct Sleeve and the wall if required
- Pipe penetration seals must be fitted a minimum of 200mm apart.

D.2.1 The line graph below shows the coverage of the allowable PVC-U circular ambient pressure extraction and ventilation 'duct' type pipe diameters and wall thickness for applications up to EI120 in minimum 100mm thick walls: (any pipe size variation along the line is covered)

PVC-U pipes fitted with minimum 250mm long Astro DS+ Low Profile (LP) Duct Sleeve (Standard Sleeve) Fire Sleeves penetrating 100mm minimum thickness flexible or rigid walls for up to EI120 applications

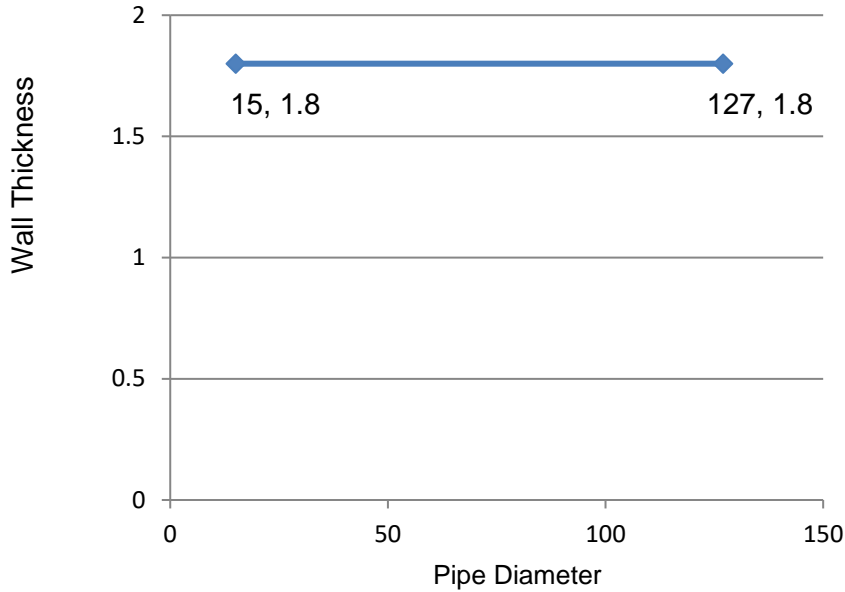

D.3 Field of application for minimum 250mm long Astro DS+ Low Profile (LP) Duct Sleeve – Circular (Enhanced Sleeve) for PVC-U circular ambient pressure extraction and ventilation ‘duct’ type pipes penetrating fire resistant walls for applications up to EI120:

Wall Thickness

The pipe may be fitted within both flexible and rigid walls constructed in accordance with section 1.2.1 of this ETA with a minimum 100mm thickness. For flexible walls using steel stud the wall can be constructed with or without cavity insulation

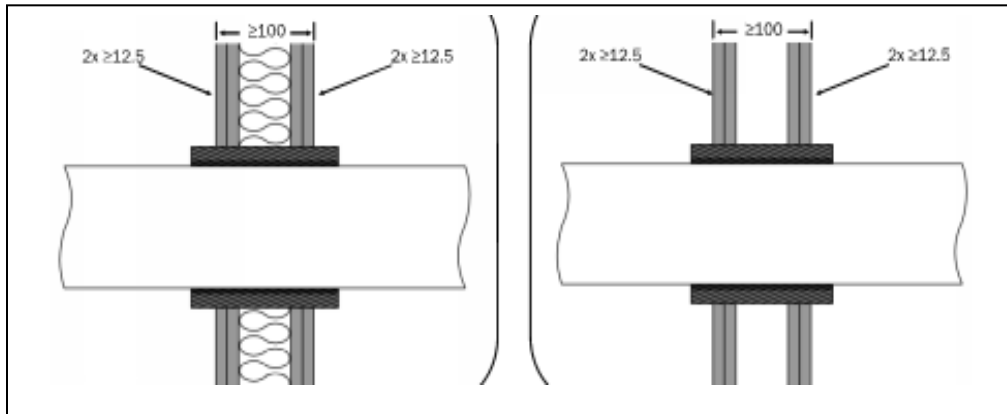

The seal must be a minimum of 250mm long with 75mm protruding each side

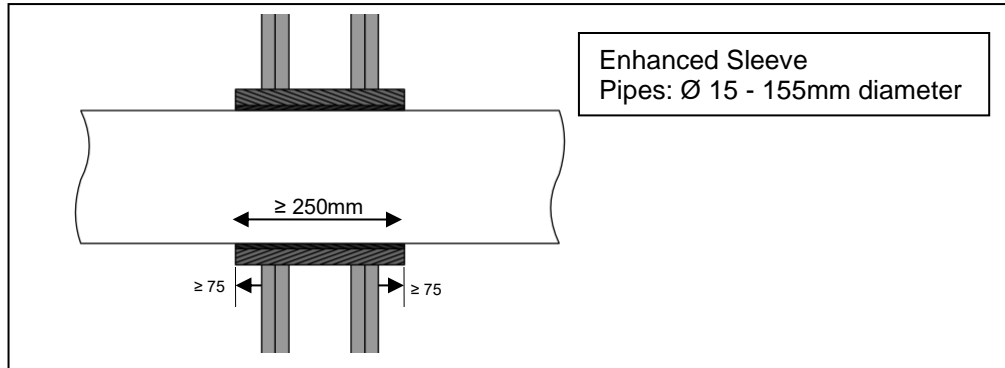

- If the wall is thicker than 100mm the seal must be longer to maintain the 75mm protruding from each face
- The seal must be friction fitted within an aperture nominally 30mm larger than the outside diameter of the pipe
- For flexible walls constructed with steel studs then the wall can be fitted with or without cavity insulation
- A support must be provided each side of the wall a maximum of 300mm from the surface of the wall
- All pipe end configurations U/U, C/U, U/C, C/C are covered for use
- Intumescent acrylic mastic may be used in addition to seal between the Astro DS+ Low Profile (LP) Duct Sleeve and the wall if required
- Pipe penetration seals must be fitted a minimum of 200mm apart.

D.3.1 The line graph below shows the coverage of the allowable PVC-U circular ambient pressure extraction and ventilation 'duct' type pipe diameters and wall thickness for applications up to EI120: (any pipe size variation along the line is covered)

PVC-U pipes fitted with minimum 250mm Astro DS+ Low Profile (LP) Duct Sleeve Circular (Enhanced Sleeve) penetrating 100mm minimum thickness flexible or rigid walls for up to EI120 applications

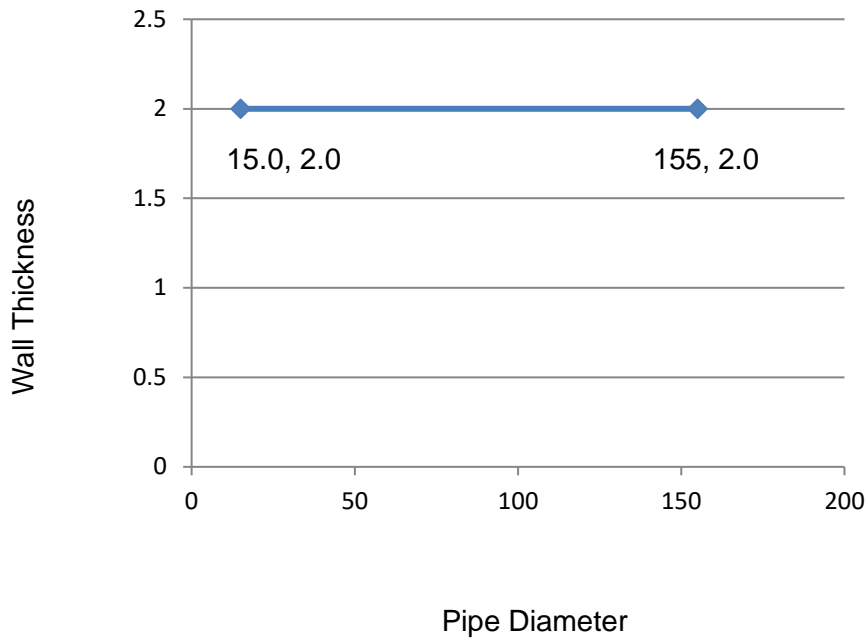

D.4 Field of application for Astro DS+ Low Profile (LP) Duct Sleeve – Rectangular (Standard Sleeve) for use with a 204mm wide x 60mm high PVC-U rectangular ambient pressure extraction and ventilation ‘duct’ type pipe penetrating fire resistant walls for applications up to EI120:

An Astro DS+ Low Profile (LP) Duct Sleeve may be used on a 204mm wide x 60mm high x 1.5 - 1.8mm wall thickness PVC-U rectangular pipe (duct) provided the following criteria are met:

- The pipe may be fitted within both flexible and rigid walls constructed in accordance with section 1.2.1 of this ETA with a minimum 100mm thickness. For flexible walls using steel stud the wall can be constructed with or without cavity insulation
- The seal must be a minimum of 150mm long with 25mm protruding each side of the wall
- The seal must be friction fitted within an aperture nominally 25mm higher and 20mm wider than the external pipe size.
- A support must be provided each side of the wall a maximum of 300mm from the surface of the wall
- Intumescent acrylic mastic may be used in addition to seal between the Astro DS+ Low Profile (LP) Duct Sleeve and the wall if required
- Pipe penetration seals must be fitted a minimum of 200mm apart
- Pipe end configurations U/U, C/U, U/C, C/C are covered for use

D.5 Field of application for Astro DS+ Low Profile (LP) Duct Sleeve – Rectangular (Standard Sleeve) for use with a 110mm wide x 54mm high PVC-U rectangular ambient pressure extraction and ventilation ‘duct’ type pipe penetrating fire resistant walls for applications up to EI120:

An Astro DS+ Low Profile (LP) Duct Sleeve may be used on a 110mm wide x 54mm high x 1.5 – 1.8mm wall thickness PVC-U rectangular pipe (duct) provided the following criteria are met:

- The pipe may be fitted within both flexible and rigid walls constructed in accordance with section 1.2.1 of this ETA with a minimum 100mm thickness. For flexible walls using steel stud the wall can be constructed with or without cavity insulation
- The seal must be a minimum of 150mm long with 25mm protruding each side of the wall
- The seal must be friction fitted within an aperture nominally 25mm higher and 20mm wider than the external pipe size
- A support must be provided each side of the wall a maximum of 300mm from the surface of the wall
- Intumescent acrylic mastic may be used in addition to seal between the Astro DS+ Low Profile (LP) Duct Sleeve and the wall if required
- Pipe penetration seals must be fitted a minimum of 200mm apart
- Pipe end configurations U/U, C/U, U/C, C/C are covered for use.

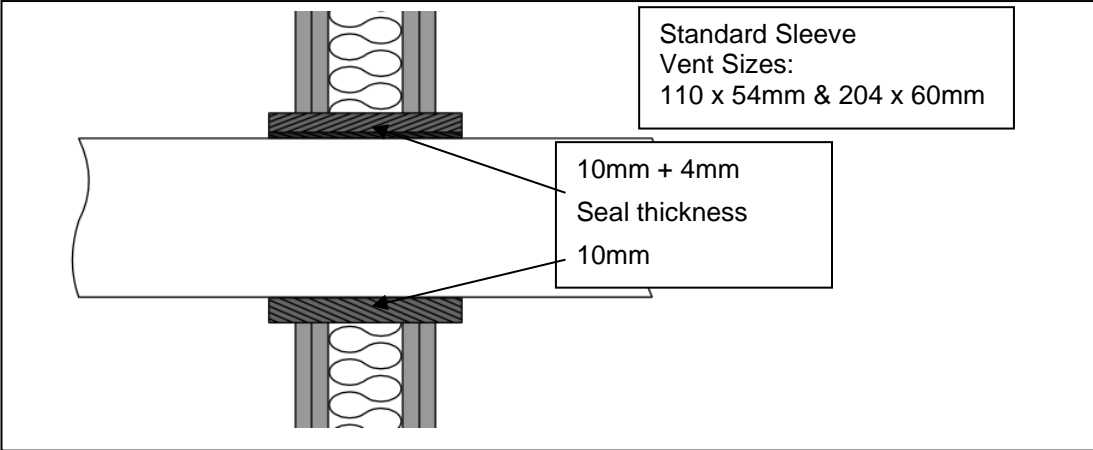

D.6 Field of application for Astro DS+ Low Profile (LP) Duct Sleeve – Rectangular (Enhanced Sleeve) for use with a 220mm wide x 90mm high PVC-U rectangular ambient pressure extraction and ventilation ‘duct’ type pipe penetrating fire resistant walls for applications up to EI120:

An Astro DS+ Low Profile (LP) Duct Sleeve may be used on a 220mm wide x 90mm high x 1.5 – 1.8mm wall thickness PVC-U rectangular pipe (duct) provided the following criteria are met:

- The pipe may be fitted within both flexible and rigid walls constructed in accordance with section 1.2.1 of this ETA with a minimum 100mm thickness. For flexible walls using steel stud the wall can be constructed with or without cavity insulation
- The seal must be a minimum of 150mm long with 25mm protruding each side of the wall
- The seal must be friction fitted within an aperture nominally 30mm higher and 20mm wider than the external pipe size.
- A support must be provided each side of the wall a maximum of 300mm from the surface of the wall
- Intumescent acrylic mastic may be used in addition to seal between the Astro DS+ Low Profile (LP) Duct Sleeve and the wall if required
- Pipe penetration seals must be fitted a minimum of 200mm apart
- Pipe end configurations U/U, C/U, U/C, C/C are covered for use.

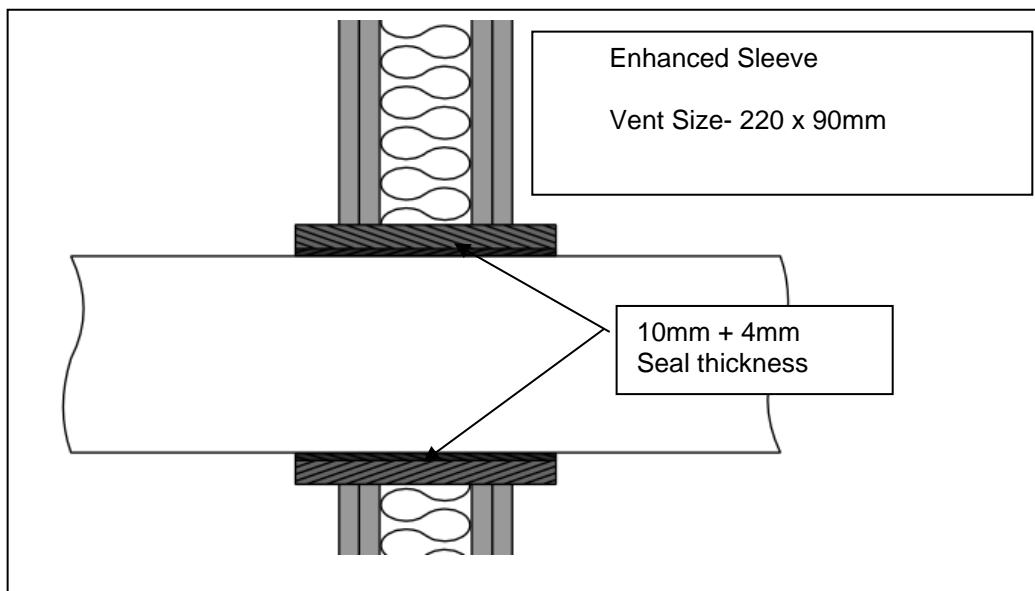

ANNEX E: DESCRIPTION OF PRODUCT(S) & PRODUCT LITERATURE

E.1 Technical Product Literature

Astroflame (fire Seals) Ltd have produced and supplied installation instructions which include the scope applicable to each installation method and the pipe type it can be used with. The information contained with this technical product literature has been checked and verified by Element Materials Technology Rotterdam B.V. as being in accordance with this ETA.

The following eight pages contain the technical product literature as supplied by Astroflame (fire Seals) Ltd for inclusion in this ETA document which will be supplied with all Astro Thermal Fire PS Fire Sleeve, Astro Thermal Fire PS+ Fire Sleeve, Astro DS Duct Sleeve, Astro DS Duct Sleeve+ and Astro DS+ Low Profile (LP) Duct Sleeve products to the market place.



Installation Instructions - Non-Combustible / Metal Pipes

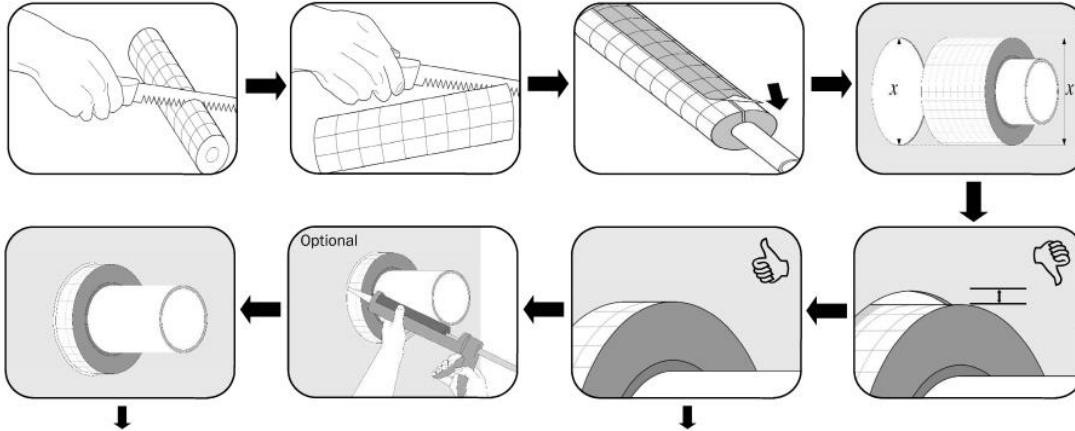

Wall Penetrations - Metal Pipes - Drywall Partition

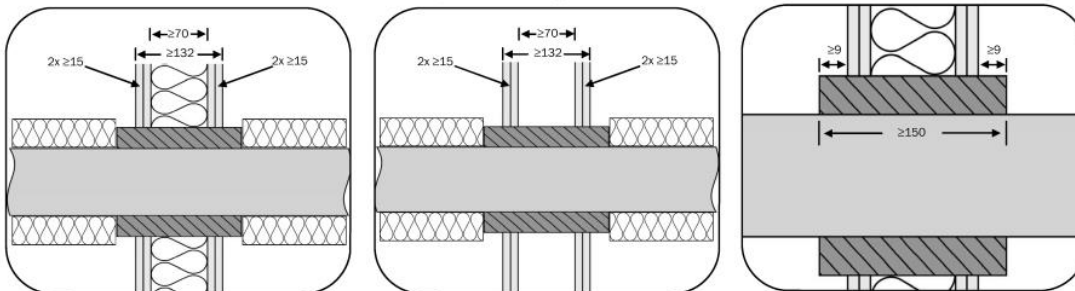

For timber stud partitions, seal must be $\ge 100\text{mm}$ from studs with $\ge 100\text{mm}$ of insulation (A1 or A2 to EN13501-1) between seal & stud.
For further details check the ETA.

Wall Penetrations - Metal Pipes - Solid Wall

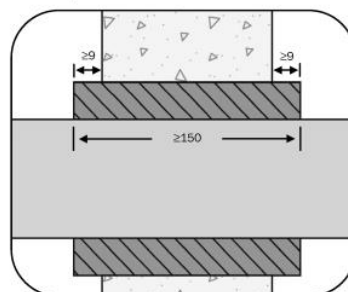
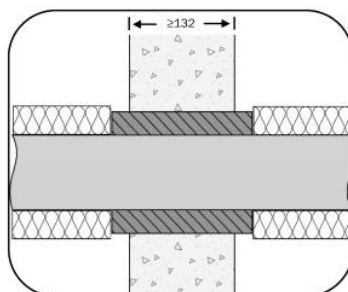

Drywall Partition / Solid Wall

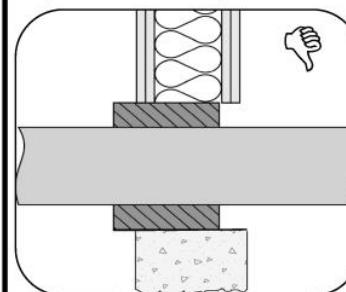

Rigid walls must comprise concrete, aerated concrete or masonry $\ge 650\text{kg/m}^3$ (Wall Type A) or concrete, masonry $\ge 1100\text{kg/m}^3$ (Wall Type B)

Approved Pipes

Mild Steel / Stainless Steel Pipes $\ge \text{Ø}15 \le \text{Ø}160\text{mm}$
Copper Pipes $\ge \text{Ø}15 \le \text{Ø}160\text{mm}$
Cast Iron Pipes $\ge \text{Ø}15 \le \text{Ø}160\text{mm}$
Wall Thickness of Pipes $\ge 1\text{mm} \le 14.2\text{mm}$ (refer to ETA for exact details)
Minimum spacing between seals $\ge 200\text{mm}$.
Pipe insulation must be continuous / stonewool / minimum 40mm thick / for further details of product type and density refer to the ETA

Fire Ratings

Tested according to BS EN 1366 Part 3 offering up to EI120 according to EN 13501.

Astro Thermal Fire PS All Approved Pipe Materials

$\ge \text{Ø}15 \le \text{Ø}160\text{mm}$	E120 C/U, U/C, C/C
$\le \text{Ø}15\text{mm}$	E120 C/U, U/C, C/C
$\ge \text{Ø}15\text{mm} \le \text{Ø}160\text{mm}$	E130 C/U, U/C, C/C



Installation Instructions - Combustible / Plastic Pipes

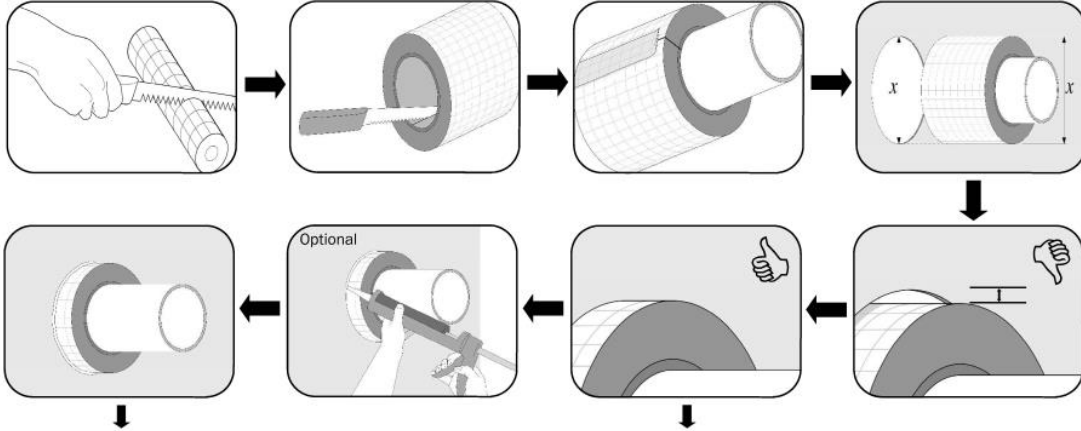

Wall Penetrations - Plastic Pipes - Drywall Partition

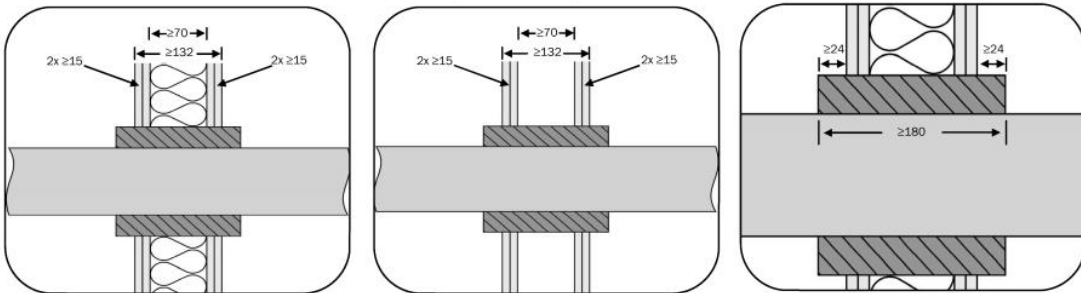

For timber stud partitions, seal must be $\geq 100\text{mm}$ from studs with $\geq 100\text{mm}$ of insulation (A1 or A2 to EN13501-1) between seal & stud.
For further details check the ETA.

Wall Penetrations - Plastic Pipes - Solid Wall

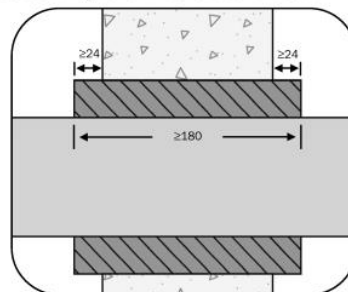
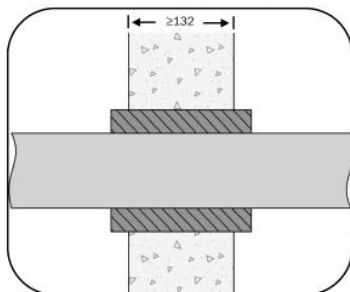

Drywall Partition / Solid Wall

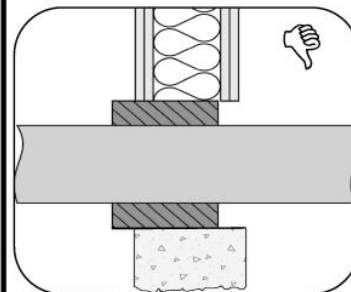

Rigid walls must comprise concrete, aerated concrete or masonry $\geq 650\text{kg/m}^3$ (Wall Type A) or concrete, masonry $\geq 1100\text{kg/m}^3$ (Wall Type B)

Approved Pipes

PVC-U Pipes $\geq \text{Ø}15 \leq \text{Ø}160\text{mm}$
HDPE Pipes $\geq \text{Ø}15 \leq \text{Ø}160\text{mm}$

Wall Thickness of PVC Pipes ranging from 1.5mm up to 3.2mm

Wall Thickness of HDPE Pipes ranging from 3.0mm up to 6.2mm

For exact details of approved pipes check the ETA

Minimum spacing between seals is $\geq 200\text{mm}$.

Fire Ratings - Wall Penetrations

Tested according to BS EN 1366 Part 3 offering up to EI120 according to EN 13501.

Astro Thermal Fire PS+

PVC-U & HDPE $\geq \text{Ø}15 \leq \text{Ø}160\text{mm}$ EI120 U/U,U/C,C/U, C/C
PVC-U 110x3.0mm (Solid Wall Only) EI240 U/U*

Astro Thermal Fire PS

PVC-U $\geq \text{Ø}15 \leq \text{Ø}160\text{mm}$ EI120 U/C, C/C
PVC-U 110x3.0mm (Solid Wall Only) EI240 U/C*
HDPE $\geq \text{Ø}15 \leq \text{Ø}110\text{mm}$ EI120 U/C, C/C
HDPE $> \text{Ø}15 \leq \text{Ø}160\text{mm}$ EI90 U/C, C/C

*EI240 - Solid Wall must be $\geq 150\text{mm}$, product length $\geq 150\text{mm}$



Installation Instructions - Combustible / Plastic Pipes

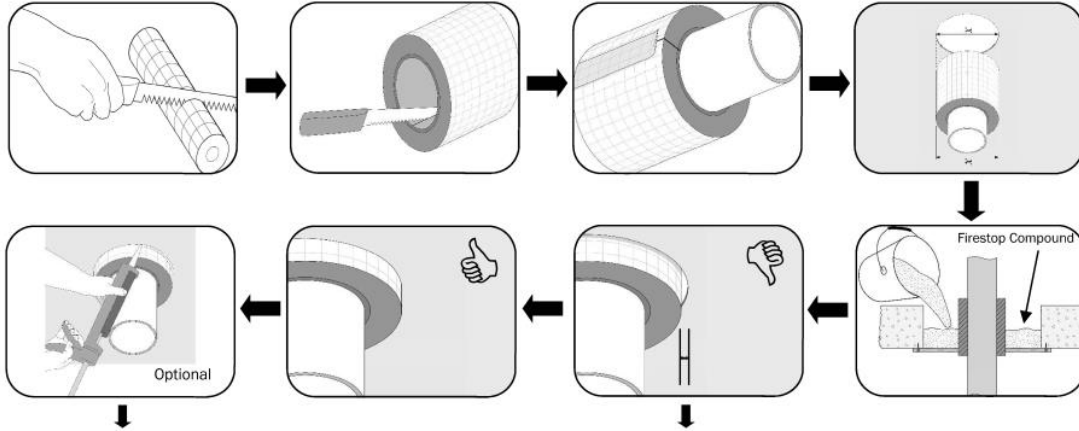

Floor Penetrations - Plastic Pipes - Solid Floor

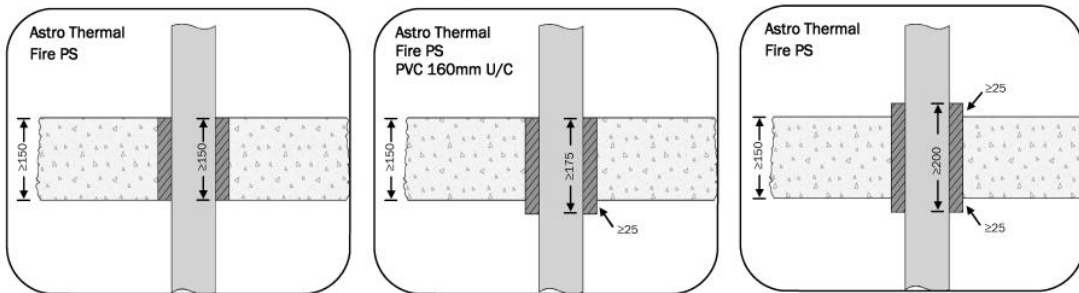

Rigid floors must comprise concrete $\geq 2400\text{kg/m}^3$ (Floor Type A) or $\geq 550\text{kg/m}^3$ (Floor Type B). For further details check the ETA

Floor Penetrations - Plastic Pipes - Solid Floor

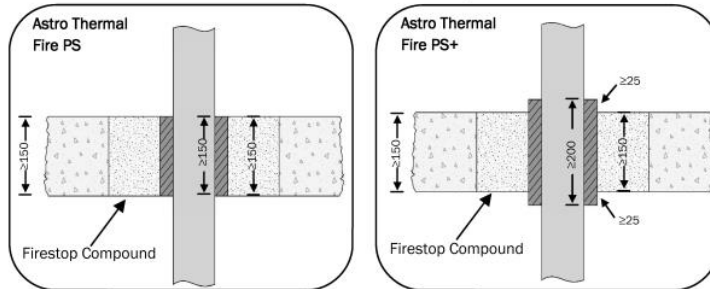

Rigid floors must comprise concrete $\geq 2400\text{kg/m}^3$ (Floor Type A) or $\geq 550\text{kg/m}^3$ (Floor Type B)

Firestop Compound to be installed as per manufacturer's instructions (for further details of approved compounds and dimensions check the ETA)

Approved Pipes

PVC-U Pipes $\geq \text{Ø}15\text{mm} \leq \text{Ø}160\text{mm}$

HDPE Pipes $\geq \text{Ø}15\text{mm} \leq \text{Ø}160\text{mm}$

Wall Thickness of PVC Pipes ranging from 3.0mm up to 3.2mm

Wall Thickness of HDPE Pipes ranging from 3.0mm up to 6.2mm

For more specific details of approved pipes check the ETA

Minimum spacing between seals is $\geq 200\text{mm}$.

Fire Ratings - Floor Penetrations

Tested to BS EN 1366 Part 3 for up to EI240 according to EN 13501.

Astro Thermal Fire PS+

PVC-U & HDPE $\geq \text{Ø}15 \leq \text{Ø}160\text{mm}$ EI120 U/U, U/C, C/U, C/C
PVC-U 110x3.0mm (Solid Wall Only) EI240 U/U, U/C, C/U, C/C

Astro Thermal Fire PS

HDPE $\geq \text{Ø}15 \leq \text{Ø}160\text{mm}$ EI120 U/C, C/C
PVC-U 110x3.0mm (Solid Wall Only) EI240 U/C, C/C
PVC-U $\geq \text{Ø}15 \leq \text{Ø}110\text{mm}$ EI120 U/C, C/C
PVC-U $> \text{Ø}15 \leq \text{Ø}160\text{mm}$ EI90 U/C, C/C

Certain coverage with either Firestop Compound or Friction Fit only, check the ETA for exact details of approved installation & pipe thickness.

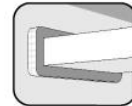

Installation Instructions - Combustible / Plastic Ventilation Ducting

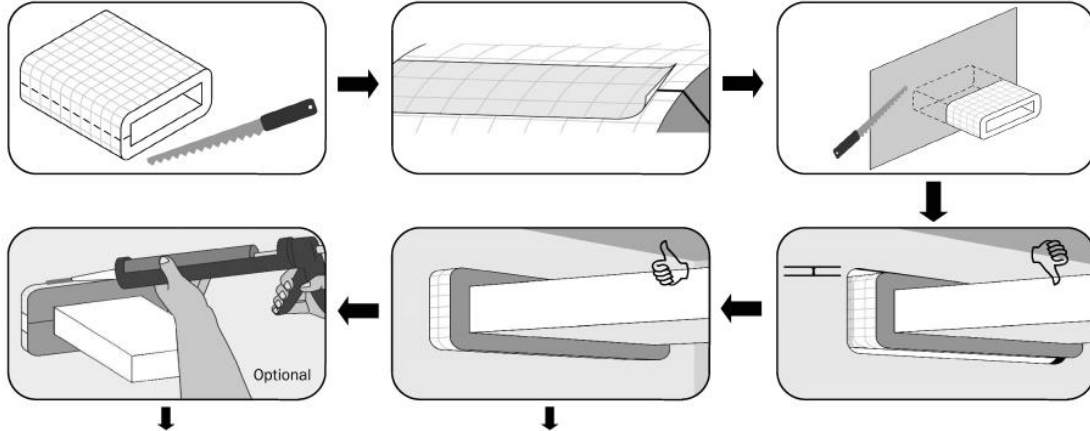

Wall Penetrations - Plastic Ducting - Drywall Partition

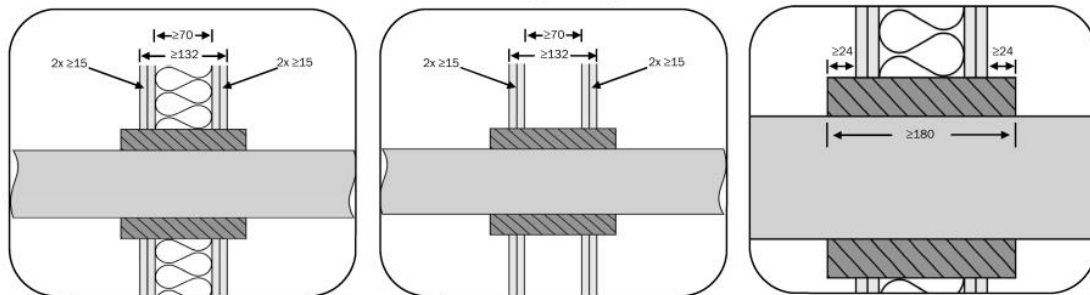

For timber stud partitions, seal must be $\geq 100\text{mm}$ from studs with $\geq 100\text{mm}$ of insulation (A1 or A2 to EN13501-1) between seal & stud.
For further details check the ETA

Wall Penetrations - Plastic Ducting - Solid Wall | Drywall Partition / Solid Wall

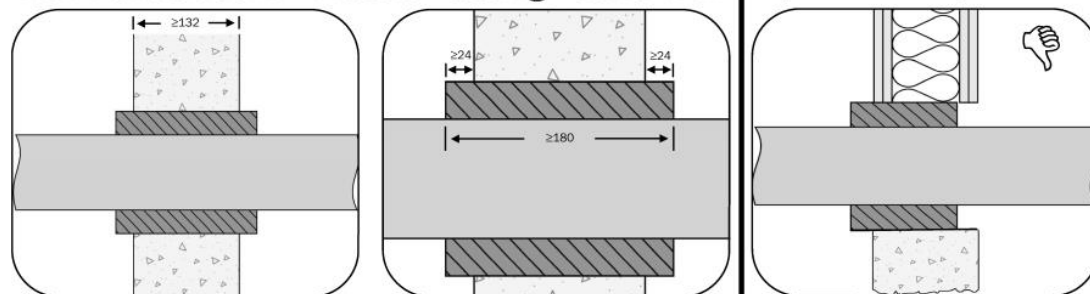

Rigid walls must comprise concrete, aerated concrete or masonry $\geq 650\text{kg/m}^3$ (Wall Type A) or concrete, masonry $\geq 1100\text{kg/m}^3$ (Wall Type B)

Approved Plastic Ducting

PVC-U Plastic Rectangular Ventilation Ducting

110 x 54mm , 204 x 60mm,
234 x 29mm & 308 x 29mm

Wall Thickness of PVC Ducts nominally 1.5-1.7mm / 1.8-2.0mm

For more specific details of approved ducting check the ETA

Minimum spacing between seals is $\geq 200\text{mm}$.

Fire Ratings - Wall Penetrations

Tested according to BS EN 1366 Part 3 offering EI120 / EI240 according to EN 13501.

110 x 54mm	EI120 U/U, C/U, U/C, C/C
204 x 60mm	EI120 U/U, C/U, U/C, C/C
204 x 60mm	EI240 U/C, C/C
204 x 60mm (DS+ only)	EI240 U/U, C/U, U/C, C/C*
234 x 29mm	EI120 U/U, C/U, U/C, C/C
308 x 29mm	EI120 U/U, C/U, U/C, C/C

*EI240 Solid Wall must be $\geq 150\text{mm}$, min. protrusion either side $\geq 15\text{mm}$



Astro Thermal Fire PS/PS+ Astro DS Duct Sleeve/+

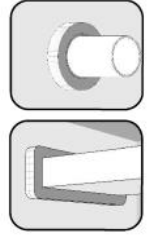

Installation Instructions - General Notes

- **Intended Use**

- **Astro Thermal Fire PS / Astro DS Duct Sleeve**

- Meets usage requirements for **Type X**: intended for use at conditions exposed to weathering.

- Astroflame recommends that Astro Thermal Fire PS & Astro DS Duct Sleeve be used for internal conditions only.

- Conditions including temperatures below 0°C and high humidity are acceptable.

- **Astro Thermal Fire PS+ / Astro DS Duct Sleeve+**

- Meets usage requirements for **Type Z¹**: intended for at internal conditions with high humidity, excluding temperatures below 0°C.

- Astroflame recommends that Astro Thermal Fire PS+ / Astro DS Duct Sleeve+ be used according to Type Z¹ conditions.

- **Maintenance**

- No maintenance work is necessary. Repair can be performed by replacing damaged Sleeves or by renewing damaged Firestop Compound (if used) as per Astroflame Fitting Instructions / Firestop Compound Manufacturer's Instructions.

- **Transportation & Storage**

- Ideally transported and stored in normal, internal and dry conditions. To avoid damage or distortion transport or store on a level foundation.

- **Shelf Life**

- Likely to be indefinite under normal storage conditions.

- **Working Life**

- The assumed working life given in the ETA is 10 years once installed provided the fire sealing product is subject to appropriate use and maintenance / repair.

- The true working life may be - in normal conditions - considerably longer without major degradation affecting the product's performance.

- The information provided on the working life cannot be interpreted as a guarantee given by the manufacturer, but should be regarded only as a means for choosing the right products in relation to the expected economically reasonable working life of the construction.

- For further details see the ETA.

- **Support of Service Penetration**

- The guidelines given in the ETA should be followed concerning the supports of the service penetration (pipe or duct).

- Wall Installation = ≤150mm each side of the wall

- Floor Installation = ≤450mm above the floor



Installation Instructions - Combustible - Plastic Vent Pipe / Ducting

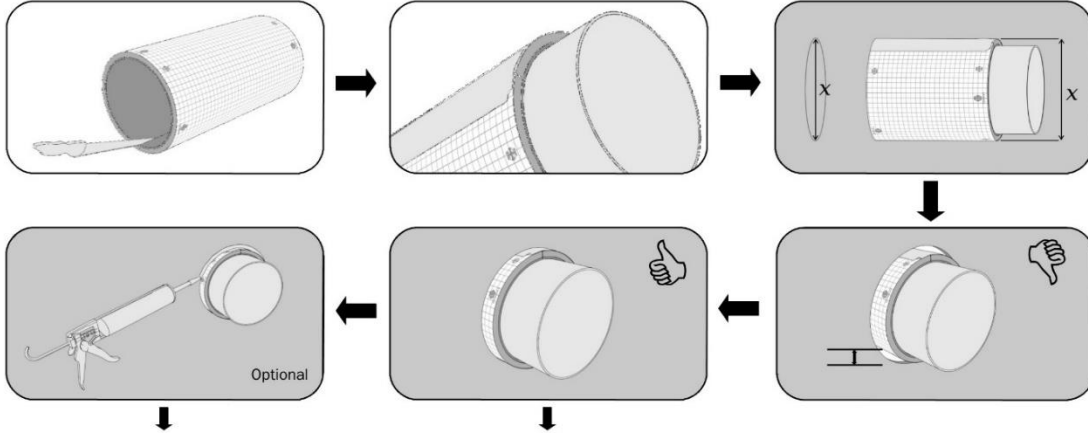

Wall Penetrations - Plastic Vent Pipe / Ducting - Drywall Partition

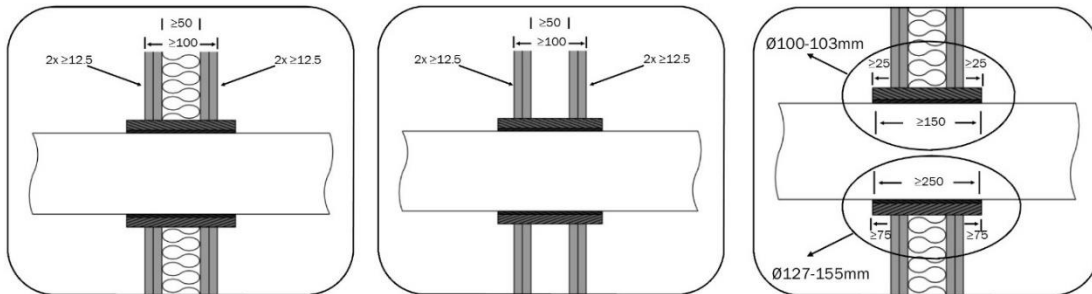

For timber stud partitions, seal must be $\geq 100\text{mm}$ from studs with $\geq 100\text{mm}$ of insulation (A1 or A2 to EN13501-1) between seal & stud.
For further details check the ETA

Wall Penetrations - Solid Wall

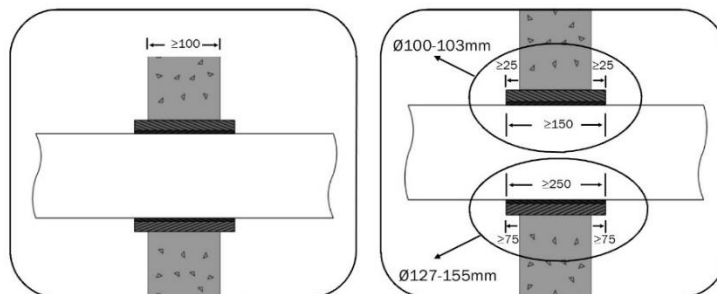

Drywall Partition / Solid Wall

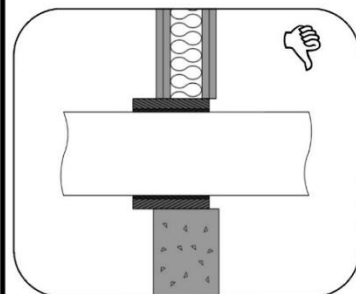

Rigid walls must comprise concrete, aerated concrete or masonry $\geq 650\text{kg/m}^3$ (Wall Type A) or concrete, masonry $\geq 1100\text{kg/m}^3$ (Wall Type B)

Approved Plastic Vent Pipe / Ducting

PVC-U Plastic Circular Ventilation Ducting

100-103mm

125-127mm

150-155mm

Wall Thickness of PVC Ducts nominally 1.5, 1.8 & 2.0mm

For more specific details of approved ducting check the ETA

Minimum spacing between seals is $\geq 200\text{mm}$.

Fire Ratings - Wall Penetrations

Tested according to BS EN 1366 Part 3 offering EI120 according to EN 13501.

ASTRO DS Low Profile Duct Sleeve

100-103mm

125-127mm

150-155mm

EI120 U/U, C/U, U/C, C/C

EI120 U/U, C/U, U/C, C/C

EI120 U/U, C/U, U/C, C/C

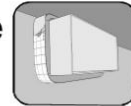

Installation Instructions - Combustible - Plastic Vent Pipe / Ducting

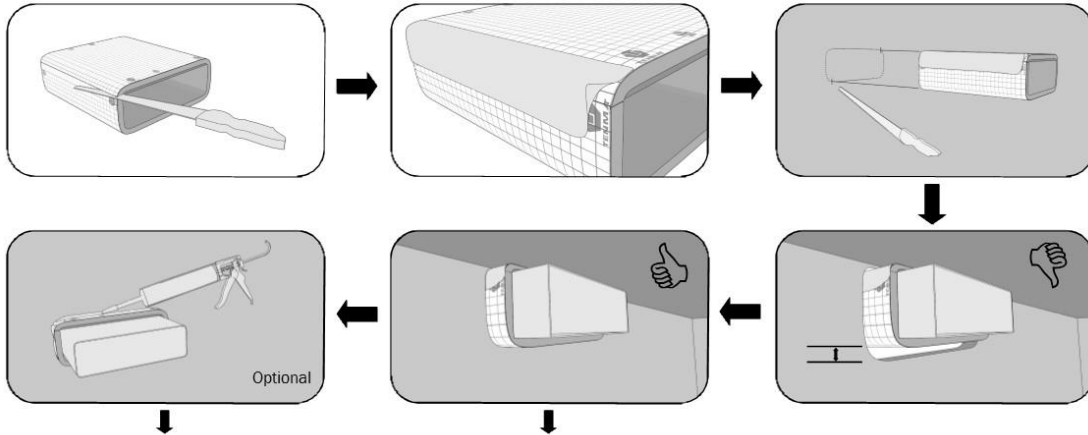

Wall Penetrations - Plastic Vent Pipe / Ducting - Drywall Partition

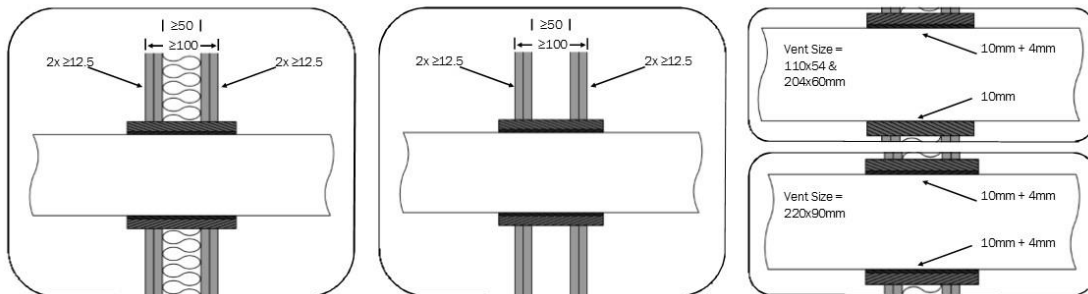

For timber stud partitions, seal must be $\geq 100\text{mm}$ from studs with $\geq 100\text{mm}$ of insulation (A1 or A2 to EN13501-1) between seal & stud.
For further details check the ETA

Solid Wall

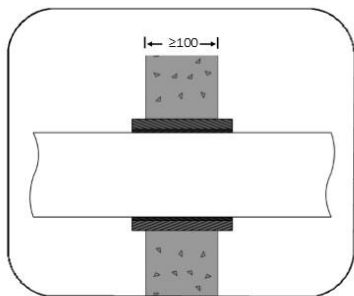

All Wall Types

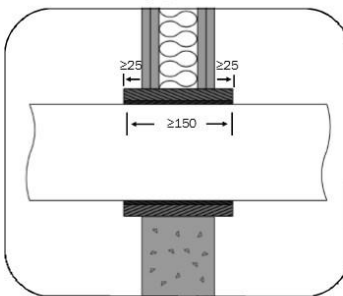

Drywall Partition / Solid Wall

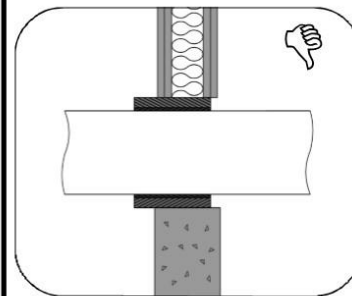

Rigid walls must comprise concrete, aerated concrete or masonry $\geq 650\text{kg/m}^3$ (Wall Type A) or concrete, masonry $\geq 1100\text{kg/m}^3$ (Wall Type B)

Approved Plastic Vent Pipe / Ducting

PVC-U Plastic Rectangular Ventilation Ducting

- 110 x 54mm
- 204 x 60mm
- 220 x 90mm

Wall Thickness of PVC Ducts nominally 1.5-1.8mm

For more specific details of approved ducting check the ETA

Minimum spacing between seals is $\geq 200\text{mm}$.

Fire Ratings - Wall Penetrations

Tested according to BS EN 1366 Part 3 offering EI120 according to EN 13501.

ASTRO DS Low Profile Duct Sleeve

- | | |
|------------|--------------------------|
| 110 x 54mm | EI120 U/U, C/U, U/C, C/C |
| 204 x 60mm | EI120 U/U, C/U, U/C, C/C |
| 220 x 90mm | EI120 U/U, C/U, U/C, C/C |

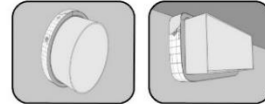

Installation Instructions - General Notes

- **Intended Use**
Astro DS+ Low Profile (LP) Duct Sleeve
Meets usage requirements for Type Z¹: intended for at internal conditions with high humidity, excluding temperatures below 0 °C.
Astroflame recommends that Astro DS+ Low Profile (LP) Duct Sleeves be used according to Type Z¹ conditions.
- **Maintenance**
No maintenance work is necessary. Repair can be performed by replacing damaged Fire Sleeves as per Astroflame Fitting Instructions.
- **Transportation & Storage**
Ideally transported and stored in normal, internal and dry conditions. To avoid damage or distortion transport or store on a level foundation.
- **Shelf Life**
Likely to be indefinite under normal storage conditions.
- **Working Life**
The assumed working life given in the ETA is 10 years once installed provided the fire sealing product is subject to appropriate use and maintenance / repair.
The true working life may be - in normal conditions - considerably longer without major degradation affecting the product's performance.
The information provided on the working life cannot be interpreted as a guarantee given by the manufacturer, but should be regarded only as a means for choosing the right products in relation to the expected economically reasonable working life of the construction.
For further details see the ETA.
- **Support of Service Penetration**
The guidelines given in the ETA should be followed concerning the supports of the service penetration (pipe or duct).
Wall Installation = ≤300mm each side of the wall